

Contents lists available at [ScienceDirect](https://www.sciencedirect.com)

Journal of Econometrics

journal homepage: www.elsevier.com/locate/jeconomFirm pay dynamics[☆]Niklas Engbom^{a,b,c,d,e}, Christian Moser^{f,b}, Jan Sauermann^{c,e,g,*}^a New York University, United States of America^b CEPR, United Kingdom of Great Britain and Northern Ireland^c IFAU, Sweden^d NBER, United States of America^e UCLS, Sweden^f Columbia University, United States of America^g IZA, Germany

ARTICLE INFO

Article history:

Received 22 August 2020

Received in revised form 13 January 2022

Accepted 27 January 2022

Available online 7 April 2022

JEL classification:

J31

D22

D31

E24

M13

Keywords:

Earnings inequality

Worker and firm heterogeneity

Firm dynamics

Linked employer–employee data

AKM

ABSTRACT

We study the nature of firm pay dynamics. To this end, we propose a statistical model that extends the seminal framework by Abowd et al. (1999) to allow for idiosyncratically time-varying firm pay policies. We estimate the model using linked employer–employee data for Sweden from 1985 to 2016. By drawing on detailed firm financials data, we show that firms that become more productive and accumulate capital raise pay, whereas firms lower pay as they add workers. A secular increase in firm-year pay dispersion in Sweden since 1985 is accounted for by greater persistence of firm pay among incumbent firms as well as greater dispersion in firm pay among entrant firms, as opposed to more volatile firm pay.

© 2022 The Authors. Published by Elsevier B.V. This is an open access article under the CC BY license (<http://creativecommons.org/licenses/by/4.0/>).

1. Introduction

A burgeoning literature studies the role of firm heterogeneity in accounting for worker-level labor market outcomes, in particular for the distribution of pay.¹ A large strand of this literature builds on the seminal econometric framework

[☆] We would like to thank the Editors, three anonymous referees, and our discussant, Douglas Webber, for constructive comments and suggestions. We are grateful to Mons Chan, Benjamin Friedrich, Émilien Gouin-Bonenfant, Jonas Hjort, Matthias Kehrig, Fabian Lange, Rasmus Lentz, Alexandre Mas, Oskar Nordström Skans, Sergio Salgado, Johannes Schmieder, Ian Schmutte, Ming Xu, and Pierre Yared for helpful discussions. We thank Patrick Kline, Raffaele Saggio, and Mikkel Sølvsten for making their codes publicly available. We also thank attendants at the 2019 Models of Linked Employer–Employee Data Conference in New York City, the 2019 German Economists Abroad Conference in Frankfurt, the 2020 Columbia Junior Micro Macro Labor Conference, the 2020 Barcelona GSE Summer Forum, and seminar participants at Columbia University and IFAU for their comments. Kerry Neitzel, Rachel Williams, and Entian Zhang provided excellent research assistance. Moser thanks the Federal Reserve Bank of Minneapolis and the Heller-Hurwicz Economics Institute at the University of Minnesota for their generous hospitality during a significant share of the period of work on this project. All errors are our own.

* Corresponding author at: IFAU, Sweden.

E-mail addresses: nengbom@stern.nyu.edu (N. Engbom), c.moser@columbia.edu (C. Moser), jan.sauermann@ifau.uu.se (J. Sauermann).

¹ See Card et al. (2018) for a recent overview of this literature. For example, Card et al. (2013) argue that increasing dispersion in pay across firms accounts for a significant share of the overall trend of increasing wage inequality in Germany, while Alvarez et al. (2018) find that a compression in firm pay was an important factor behind a large decline in earnings inequality in Brazil over the past decades.

by [Abowd, Kramarz, and Margolis \(1999\)](#), henceforth AKM), which allows researchers to separately identify unobserved, time-invariant worker and firm pay heterogeneity. While this framework has greatly expanded our understanding of the working of the labor market, it rests on the strong assumption that firm pay is constant over time. In contrast, canonical models of firm dynamics postulate that firms pass through aggregate or firm-level productivity shocks to workers' pay ([Moscarini and Postel-Vinay, 2013](#); [Coles and Mortensen, 2016](#)). This raises a sequence of important questions: Does an assumption that firm pay is fixed understate the contribution of firms toward earnings inequality? Exactly how dynamic is firm pay? And why do firms adjust their pay over time?

To answer these questions, we develop a statistical model that allows us to study firm pay dynamics. To this end, we extend the seminal AKM framework to allow for idiosyncratically time-varying firm pay via a set of flexible firm-year fixed effects (henceforth FEs). The key advantage of our model is that it allows us to relax the assumption of constant firm pay, on which the seminal AKM framework relies. We show that, analogous to the usual notion of a connected set ([Abowd et al., 2002](#)), the firm-year FE model is identified for a set of firms and workers that are linked through worker transitions between firm-years.

To quantify the importance of firm-year pay heterogeneity, we estimate a firm-year FE specification on 32 years of Swedish linked employer–employee data from 1985–2016. Our estimates imply that firm-year FEs are not constant, but quite persistent. For instance, in an unbalanced panel, the autocorrelation between firm pay in a given year and ten years later is around 0.75. At the same time, we document that firm pay changes significantly with firm fundamentals. Moreover, the nature of such changes in firm pay is consistent with the predictions of common models of firm dynamics, in which firms share some of their marginal product of labor with workers.² For instance, holding fixed employment and capital, a firm that becomes more productive raises pay; the same is true for a firm that accumulates capital, holding fixed employment and productivity. In contrast, holding fixed capital and productivity, a firm tends to *lower* pay as it increases its employment, although the relationship between changes in pay and changes in employment depends on the time horizon and is not always statistically different from zero.

Turning to inequality patterns, results based on plug-in estimates indicate that firm-year FEs account for 16 percent of the overall variance of log monthly earnings. To address limited-mobility bias in the estimated variances of the FEs, we adopt the leave-one-out bias correction proposed by [Kline et al. \(2020\)](#), henceforth KSS). Under the KSS bias correction, we find that firm-year FEs account for 14 percent of the variance of log monthly earnings, similar to our baseline estimates. In contrast, when firm pay heterogeneity is assumed to be fixed, firms account for 13 (12) percent of the variance of log monthly earnings under the plug-in method (KSS bias correction). Hence, allowing for within-firm fluctuations in pay raises the statistical contribution of firms toward earnings inequality by 19–24 percent.

Under the plug-in method (KSS bias correction), the contribution of the worker FEs toward overall earnings inequality rises from 36 (30) percent when firm pay heterogeneity is assumed fixed, to 36 (32) percent when firm pay is allowed to vary. Hence, the increasing explanatory power of firms under the firm-year FEs specification does not appear to come at the expense of a smaller statistical role of workers. Two times the covariance between worker and firm-year (firm) FEs accounts for 1–2 percent of earnings inequality across all models (firm and firm-year, plug-in method and the KSS bias correction). From this, we conclude that the firm-year FEs model assigns a greater statistical role for firms in accounting for earnings dispersion primarily at the expense of a lower variance of the residual.

We apply our estimated framework to understand changes in earnings inequality in Sweden over the past 32 years. Dispersion in firm-year pay has increased over this period, mirroring findings of increased dispersion in pay between firms in, for instance, Germany ([Card et al., 2013](#)) and the US ([Song et al., 2018](#)). Moreover, we show that although temporary fluctuations in firm pay is a nontrivial source of overall firm pay dispersion, the increase in firm pay dispersion is accounted for by a higher persistence of shocks among incumbent firms as well as greater pay dispersion among firms already at entry, as opposed to a higher dispersion in post-entry innovations to firm pay. These findings are made possible by the application of our firm-year FEs model and would have remained hidden in analyses based on a static firm FEs model.

Altogether, our findings suggest that firm pay is dynamic and, although more persistent over shorter time horizons, varies substantially over 32 years of Swedish data in ways that are tied to economically meaningful firm characteristics.

Related literature. The increasing availability of administrative linked employer–employee datasets has spurred a large empirical literature on the determinants of worker and firm heterogeneity in wage determination. The econometric framework commonly employed in this literature is the seminal two-way FEs model by AKM, which identifies worker and firm FEs separately from workers switching employers over time. Many studies have built on this framework and highlighted the importance of firm FEs in explaining both cross-sectional patterns of wage dispersion and time trends in wage dispersion. To study cross-sectional wage dispersion, an econometrician would commonly estimate the AKM model within a fixed time window ([Abowd et al., 2002](#); [Card et al., 2018](#); [Sorkin, 2018](#); [Bassier et al., 2021](#)). To study time trends in wage dispersion, previous work has estimated AKM models within rolling time windows and compared cross-sectional estimates across time windows ([Card et al., 2013](#); [Song et al., 2018](#); [Alvarez et al., 2018](#)). We complement this literature with a model that allows for idiosyncratically time-varying firm pay.

To allow for firm-specific fluctuations in pay seems natural in light of a large parallel literature studying the pass-through of firm-level shocks to worker-level outcomes ([Van Reenen, 1996](#); [Guiso et al., 2005](#); [Lemieux et al., 2009](#);

² For instance because labor markets are characterized by frictions, giving firms monopsony power over workers.

Card et al., 2014; Kline et al., 2019; Garin and Silvério, 2019; Kehrig and Vincent, 2019; Chan et al., 2021; Moser et al., 2022). Much of this literature is concerned with estimating rent-sharing elasticities for incumbent workers who remain employed. Recent exceptions include Balke and Lamadon (2020) and Friedrich et al. (2021), who explicitly model worker mobility between firms. Relative to previous work, our empirical approach has the advantage that, first, we do not need to take a stance on the sources of the fluctuations in firm pay and, second, we obtain worker selection-corrected estimates of firm pay that exploit information on both stayers and movers over time.

In contemporaneous work, Lachowska et al. (2021) develop a similar framework for estimating firm-year pay heterogeneity with leave-one-out bias corrections based on the method by KSS, which they apply to data from the US state of Washington from 2002–2014 (i.e., 13 years). Our works share the application of such a framework to study time trends in firm pay. Notable aspects that distinguish our work from theirs include our use of data covering a significantly longer time period from 1985–2016 (i.e., 32 years), our analysis of detailed firm financials data, and our application linking firm pay dynamics to inequality trends in Sweden. Our application demonstrates that a dynamic model of firm pay can shed new light on important issues relating to earnings inequality in relation to worker and firm heterogeneity.

Our empirical findings also help discipline a new generation of structural models of firm heterogeneity in the labor market. While, traditionally, a large class of models have assumed that firm heterogeneity in pay and underlying characteristics such as productivity is fixed (Burdett and Mortensen, 1998; Bagger and Lentz, 2018; Engbom and Moser, 2021), a new generation of models allows for rich dynamics of firms in the labor market (Moscarini and Postel-Vinay, 2012; Lise and Robin, 2017; Moscarini and Postel-Vinay, 2018; Bilal et al., 2021; Elsyby and Gottfries, 2021). These models are silent about the nature of wage setting, as only the value or surplus of a match is theoretically pinned down. Our rich set of empirical facts on firm pay dynamics can help discipline the wage setting side of these models, which is of great interest for further structural work tying together firm dynamics and worker-level outcomes, including pay.

Outline. The rest of the paper is structured as follows. Section 2 describes the linked employer–employee and firm financials data from Sweden. Section 3 introduces the firm-year FEs model. Section 4 analyzes our estimates of firm-year FEs and compares them to estimates from the canonical firm FEs model. Section 5 applies the firm-year FEs model to shed new light on changes in Swedish earnings inequality in relation to firm pay dynamics. Finally, Section 6 concludes.

2. Data

In this section, we describe our data sources, discuss variable definitions and sample selection, present general summary statistics, and take a first look at firm pay dynamics in the data.

2.1. Data sources

To study firm pay dynamics, we link four administrative registers to create a linked employer–employee dataset covering the near-universe of workers and firms in Sweden. The underlying data are originally reported to Swedish government agencies and subsequently consolidated by the Swedish statistical agency, *Statistiska Centralbyrån (SCB)*, to make them available in anonymized form to approved researchers. These data have some advantages over comparable data available in the US and many other countries. Notably, they contain information on the characteristics of essentially all workers, firms, and jobs in the economy, including detailed firm financials for a subperiod of substantial length.³

The *Registerbaserad Arbetsmarknadsstatistik (RAMS)* dataset contains information on the universe of employment biographies, including a measure of monthly earnings as well as firm and establishment identifiers to link workers, firms, and establishments. The RAMS covers all employment spells ever active at some point between 1985–2016.

The *Longitudinell Integrationsdatabas för Sjukförsäkrings- och Arbetsmarknadsstudier (LISA)* and *Longitudinell Databas om Utbildning, Inkomster och Sysselsättning (LOUISE)* databases provide detailed demographic information on all individuals aged 16–70 between 1985–2016, including workers' gender, year of birth, and their educational degree.⁴

Finally, we obtain firm financials data from the *Företagens Ekonomi (FEK)*. The FEK is available for close to the universe of Swedish firms since 1997. Prior to 1997, FEK covers a nonrandom sample of primarily large firms. To sidestep these compositional changes, we focus our analysis of firm financials to the 1997–2016 subperiod, while continuing to use the full period 1985–2016 for other statistical analyses. While FEK provides some information at the establishment level, we focus on the more comprehensive firm-level data throughout this paper.⁵

³ Appendix A.1 presents additional information on the main datasets.

⁴ The detailed demographic data from LISA start in 1990. We obtain earlier records – including gender, year of birth, and educational degree – from the predecessor to LISA, namely LOUISE, prior to 1990.

⁵ A “firm” in the Swedish administrative data is similar to the concept of an EIN number in US administrative data sets—it may have multiple establishments, but there are also instances of firms sharing ownership through a parent holding company.

2.2. Variable definitions

Our main outcome variable of interest throughout the analysis is monthly earnings, defined as mean monthly gross earnings over an individual's main employment spell each year (henceforth “earnings”). This earnings measure falls somewhere in between annual earnings (i.e., the sum of all labor income in an employment spell each year, regardless of the months of employment or hours worked) and hourly wages (i.e., labor income per hour worked in an employment spell each year) in that it accounts for the extensive, but not the intensive, margin of employment. For workers with multiple employment spells per year, we select a worker's main employment spell, defined as the employment with the highest earnings in each year. Earnings are deflated using Sweden's national consumer price index. Before estimating wage equations, we also demean all data by subtracting gender-education-specific means from log earnings each year.⁶

Other variables are constructed as follows. We take worker age and gender directly from LISA and LOUISE. Using information from LISA and LOUISE, we fix education within an individual to the highest degree received at any point during our panel over 32 years. To this end, we aggregate educational attainment into five categories, roughly corresponding to the US equivalents of less than high school, high school, some college, college, and postgraduate studies. The RAMS data, which contain the universe of employment spells, allows us to calculate the number of workers per firm as well as to create right-censored measures of firm age and tenure within worker–firm matches. Lastly, the FEK contains information on value added and the book value of a firm's capital stock.

Since the remainder of our analysis will be concerned with firms, it is worth noting that the notion of a firm in the Swedish administrative data is based around tax-registered employment centers, making it similar to the notion of a firm in comparable US datasets (i.e., similar to a US employment identification number, or EIN).

While the Swedish administrative data are exceptionally rich in many regards, one particular drawback is worth noting: The data lack information on work hours for much of the population. Since 1992, data on hours worked are regularly collected only for a fairly homogeneous subset of public sector employers and for large firms with more than 500 employees. Smaller employers are randomly sampled each year, making it difficult to adapt the data to our longitudinal analysis. For these reasons, our analysis abstracts from hours worked. To the extent that firms change their work hours in a coordinated fashion over time, this means that some of the empirical variation in firm pay that we estimate may reflect such variation in work hours.⁷

2.3. Sample selection

We focus on individuals between 20 and 59 years in age. In our baseline empirical analysis, we study the full period 1985–2016. When we subsequently link firm pay dynamics to firm financial outcomes, we restrict attention to the subperiod 1997–2016, corresponding to the years for which we have close-to-complete coverage of the FEK data.⁸

Because the employment register data cover all employment spells, including part-time jobs, a non-trivial share of spells are associated with relatively low levels of reported earnings. To limit the impact of outlier observations, we drop the bottom five percent of earnings in each year. While we think this truncation is reasonable, we have experimented with more and less stringent cutoffs without substantially affecting our results.

We restrict our analysis to the largest leave-one-out connected set of workers and firms as in KSS, details of which we discuss below. In practice, this restriction drops a significant share of (mostly small and sparsely connected) firms while retaining a relatively larger share of workers and worker-years. Finally, when implementing the KSS correction for wage variance components, but not otherwise, we further drop a small share of singleton worker observations, consisting of workers that are observed for only a single year from 1985–2016.

2.4. Summary statistics

Table 1 summarizes the data in our sample. In total, the merged dataset comprises almost 90 million individual-year observations, over six million unique workers, over two million firm-years, and close to 300 thousand unique firms. The average worker age is just below 40 years, around 19 percent hold a higher-education degree, and men constitute a slight majority among Swedish workers in our sample.

Fig. 1 summarizes the evolution of the earnings distribution in Sweden between 1985 and 2016. Panel (a) of Fig. 1 shows the variance of demeaned log earnings. After a steady increase between 1985 and 2004, the variance decreased slightly and then stabilized from around 2006 onwards. Apart from these long-term trends, there were noticeable upticks

⁶ In theory, a set of (gender-education-specific) year FEs could be included in the estimation. However, the inclusion of (gender-education-specific) year FEs requires a normalization on the set of firm-year FEs to be estimated, which turns out to be prohibitively expensive in terms of computational power required for the KSS leave-one-out bias correction. Related work by Lachowska et al. (2021) omits all controls from their analysis and does not restrict their sample by worker demographics such as age.

⁷ See also Lachowska et al. (2021) for an analysis of quarterly earnings versus hourly wages using administrative linked employer–employee data from the US state of Washington.

⁸ For our analysis of the subperiod 1997–2016 using firm financials, we continue to draw on our estimates of the baseline wage equation for the full period 1985–2016.

Table 1
Summary statistics.
Source: LISA, LOUISE, and RAMS, 1985–2016, and FEK, 1997–2016.

	Mean	St.d.
<i>Panel A. Worker-level variables</i>		
Worker age (years)	39.706	11.235
Share with college degree	0.258	0.437
Share female	0.480	0.500
<i>Panel B. Firm-level variables</i>		
Log capital	15.818	1.759
Log number of workers	2.047	1.202
Labor value added per worker	13.125	0.590
<i>Panel C. Observations</i>		
Number of worker-years	90,909,217	
Number of unique workers	5,967,674	
Number of firm-years	2,170,667	
Number of unique firms	278,824	

Note: Panel A shows worker-level outcomes; Panel B shows firm-level outcomes (i.e., not employment-weighted). All individuals aged 20–59 who earn above the bottom fifth percentile of earnings in a year. College degree refers to a Bachelor’s degree or higher. Capital is the book value of assets in log real SEK, size is the log of the average number of employees of a firm during the year, and labor productivity is value added per worker in log real SEK per employee, where value added is the sum of annual sales minus costs of intermediates.

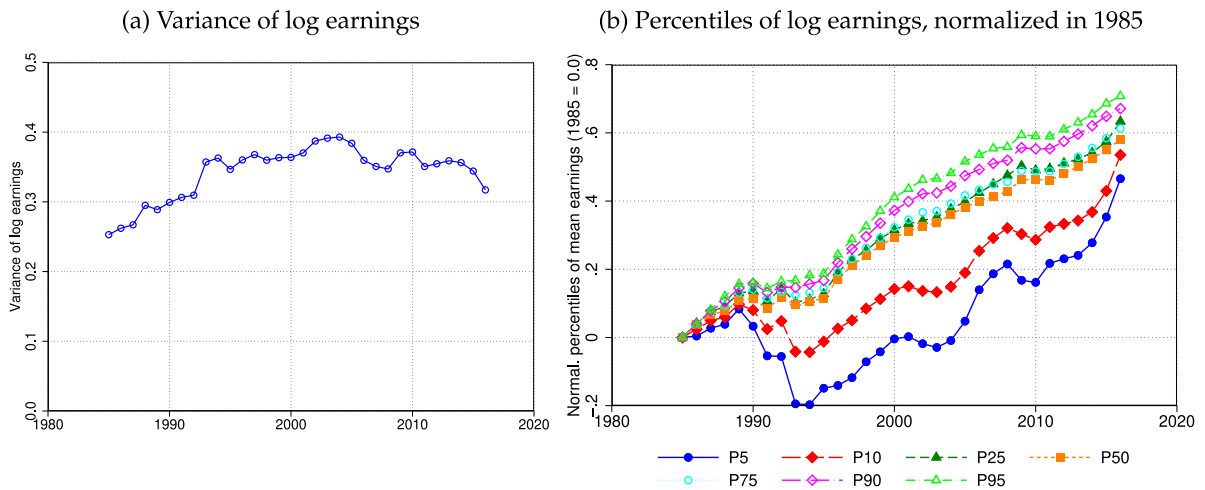

Fig. 1. Evolution of the earnings distribution in Sweden. Note: panel (a) shows the variance of demeaned log earnings from 1985 to 2016; panel (b) shows percentiles of the log real earnings distribution, normalized to 0 in 1985. Source: LISA, LOUISE, and RAMS, 1985–2016.

in the variance around 1993 and 2009, corresponding to the Swedish financial crisis of the early 1990s and the global financial crisis of the late 2000s.

Panel (b) of Fig. 1 sheds further light on these inequality trends by showing percentiles of the log real earnings distribution, normalized to 0 in 1985. There was widespread real earnings growth throughout the period from 1985 to 2016 except for three episodes: the Swedish financial crisis from 1990–1994, the 2000–2003 recession, and the aftermath of the more recent global financial crisis from 2008–2010. Gradually throughout this period, earnings growth at higher earnings percentiles (e.g., the P95 and the P90) significantly outpaced that at lower earnings percentiles (e.g., the P5 and P10). For example, the P5 of the real earnings distribution grew by 47 log points, while the P95 grew by 71 log points over the period from 1985–2016. An exception to this pattern is that the P25 grew slightly faster than, say, the P50 or the P75.

2.5. Summarizing raw firm pay dynamics

A long literature has taken the view that firms are dynamic objects, both at the intensive margin – e.g., pay, number of employees, and productivity – and at the extensive margin—entry and exit. To corroborate this view, we start by establishing some patterns of firm dynamics in Sweden between 1985 and 2016.

Table A.1 in Appendix A.2 presents autocorrelations of raw (i.e., not controlling for any other covariates) firm-level mean log earnings in year $t = 1985, \dots, 2016$ and future year $\tau = t, \dots, 2016$. According to the unweighted firm-level statistics in Panel A, the one-year correlations are between 0.70 and 0.85. The unweighted 32-year correlation between 1985 and 2016 is 0.50. Looking at the employment-weighted worker-level statistics in Panel B, the one-year correlations are between 0.83 and 0.94 and the 32-year correlation between 1985 and 2016 is 0.69. Together, these statistics suggest two insights. First, firm pay is persistent but not permanent. Second, employment tends to be concentrated at firms that have more persistent pay.

These observations suggest an important role for firm pay dynamics. However, there are two possible explanations for the observed pattern of firm pay dynamics. On one hand, these patterns may reflect changes in firm pay policies, for example reflecting pay changes in response to firms' idiosyncratic state or in response to a firm-specific loading on the aggregate state. On the other hand, these patterns may reflect changes over time in worker composition across firms, which manifests itself in firm-level earnings fluctuations. The contribution of this paper, which we flesh out in Section 3, is to propose and implement a framework that allows us to distinguish between these two sources of firm pay dynamics: changes in firm pay policies versus changes in worker composition.

Next, we turn to firm survival rates. An important margin of adjustment among firms is the decision to stay in business or shut down (Haltiwanger et al., 2013). To illustrate the importance of this margin in our context, Table A.2 in Appendix A.2 shows the share of Swedish firms in year $t = 1985, \dots, 2016$ who survive until year $\tau = t, \dots, 2016$, both unweighted (Panel A) and weighted (Panel B). Two key insights emerge from this analysis. First, there is a large amount of business turnover in the form of firm exit. Second, employment tends to be concentrated at firms that are less likely to exit. These points are important to keep in mind when we study unbalanced versus balanced panels in the remainder of the analysis.

3. Measuring firm pay dynamics

In this section, we introduce a statistical model of firm pay dynamics by building on the seminal econometric framework due to AKM. Our goal is to estimate empirical firm pay dynamics while controlling for worker composition. Economic theories predict that pay policies may be heterogeneous across firms due to labor market frictions (Burdett and Mortensen, 1998), compensating differentials (Rosen, 1986), or both (Morchio and Moser, 2020). Related theories predict that firm pay policies may change idiosyncratically due to either heterogeneous pass-through of aggregate shocks (Moscarini and Postel-Vinay, 2013) or pass-through of firm-level productivity shocks (Coles and Mortensen, 2016), changes in firm financial conditions (Moser et al., 2022), or firm life-cycle dynamics (Babina et al., 2019).

3.1. Econometric framework: The firm-year FEs model

We posit the following firm-year FEs model for pay of individual i in year t while employed at firm $j = J(i, t)$:

$$y_{ijt} = \alpha_i + \psi_{jt} + \mathbf{X}_{it}\boldsymbol{\beta} + \varepsilon_{ijt}, \quad (1)$$

where y_{ijt} is log earnings, α_i is a worker FE, ψ_{jt} is a firm-year FE, \mathbf{X}_{it} is a vector of time-varying worker controls with coefficient vector $\boldsymbol{\beta}$, and ε_{ijt} is an error term.

Our object of interest in Eq. (1) are the firm-year FEs, ψ_{jt} , which we interpret as time-varying firm pay policies.⁹ These time-varying firm pay policies take the form of log-additive pay premia for any worker i at a given physical firm j in some year t .

The specification in Eq. (1) controls for time-varying observable worker characteristics (\mathbf{X}_{it}), specifically a restricted set of age dummies for each gender-education group.¹⁰ Due to the well-known problem of collinearity between age, cohort, and time, it is not feasible to include unrestricted age dummies or a linear term in age (Card et al., 2018). Rather than imposing a functional form (usually second- or higher-order polynomial in age) and an exact peak of the pay-age profile (usually a few years before retirement age) as in previous work, we normalize age dummies to be constant between ages 50 to 51 based on the raw earnings profile being approximately flat around those ages. This has the advantage of estimating more flexible life-cycle pay profiles that are allowed to vary freely outside of the normalization window.¹¹

In addition to accounting for observable worker characteristics (\mathbf{X}_{it}), the inclusion of worker FEs (α_i) in Eq. (1) allows us to separately control for unobservable but permanent worker heterogeneity, including the wage component due to constant worker ability. Accounting for worker heterogeneity has proven to be of first-order importance in a number of contexts, including labor markets where heterogeneous workers are not uniformly allocated across firms (Card et al.,

⁹ Note that ψ_{jt} in theory also contains a year FE, although in practice the cross-year variation in yearly means of firm-year FEs is close to zero, since we demeaned earnings by subtracting gender-education-year-specific means from raw log earnings before estimating wage Eq. (1).

¹⁰ As a robustness check, we have estimated a variant of this specification including a set of tenure dummies, without significant changes to the resulting variance decomposition. Because our computed tenure variable is right-censored and thus changes across years, we prefer the baseline specification that uses a consistent set of controls over the entire 1985–2016 period.

¹¹ An additional advantage of this method is that, ex-post, the researcher can check for discontinuities or kinks in the estimated life-cycle age profiles around the flat region in order to validate the identifying assumption of a flat part.

2013; Alvarez et al., 2018; Song et al., 2018). These controls are crucial because without them it would be impossible to tell apart true changes in firm pay policies from changes in worker composition along unobserved dimensions. In this sense, our estimates of time-varying firm pay policies (ψ_{jt}) are correcting for time-varying worker selection based on permanent worker heterogeneity (α_i).

3.2. Relation to the firm FEs model

The simple but important difference between our specification in Eq. (1) and the original specification due to AKM is that our specification allows for time-varying firm-year FEs (ψ_{jt}) instead of permanent firm FEs (ψ_j), as in AKM and a vast follow-up literature, which have estimated wage equations of the following type:

$$y_{ijt} = \alpha_i + \psi_j + \mathbf{X}_{it}\boldsymbol{\beta} + \varepsilon_{ijt}, \quad (2)$$

where y_{ijt} is log earnings, α_i is a worker FE, ψ_j is a firm FE, \mathbf{X}_{it} is a vector of time-varying worker controls with coefficient vector $\boldsymbol{\beta}$, and ε_{ijt} is an error term. Relative to the firm FEs model in Eq. (2), our framework represents a generalization of the canonical econometric framework due to AKM by relaxing the assumption of constant firm pay policies.

An advantage of the firm-year FEs model over the traditional AKM model with firm FEs is that the former reduces to the latter if in reality firm pay policies are time invariant.¹² Conversely, the AKM model with firm FEs is misspecified if true firm pay policies are time varying.

A popular alternative approach to estimating changes in the variance of AKM wage components is a rolling time window model (Card et al., 2013; Alvarez et al., 2018; Lachowska et al., 2021). The rolling time window model repeatedly estimates firm FEs models within (overlapping) subperiods. A potential advantage of the rolling time window approach is that, in principal, it allows for time-varying unobserved worker heterogeneity. However, one of its disadvantages is that, to the extent that one observes within-firm (within-worker) variation in estimated firm (worker) FEs across time windows, the model is generally misspecified.

In Section 4.1, we compare firm-year FEs estimated over the whole period with firm FEs and, separately, firm-year FEs estimated over separate subperiods.

3.3. Identification of the firm-year FEs model

Identification of the firm-year FEs model proceeds analogously to that of the firm FEs model due to AKM. There are two important aspects of identification: connectedness and strict exogeneity.

Connectedness. As in the original firm FE framework due to AKM, we restrict attention to workers and firms within a connected set in order to circumvent multicollinearity between subsets of worker and firm FEs (i.e., to guarantee full rank and thus invertibility of the Gramian matrix). The only material difference in the present setting is that the notion of a “physical firm” in the firm FEs model is replaced with a “firm-year combination” in the firm-year FEs model. To see this, it will be useful to revisit the definition of connectedness, first in the context of the firm FEs model due to AKM and then in the context of our firm-year FEs model.¹³

First, recall the notion of a connected set in the context of the firm FEs model due to AKM. Identification of the firm FEs model is obtained within connected sets of observations, where connections are formed through worker mobility across physical firms (Abowd et al., 2002). Physical firms can exist for multiple years, connected sets are defined by switches between physical firms, and workers moving between physical firms constitute switches. Firm FEs within a connected set are relative to the FE of one normalized physical firm. Intuitively, changes in residual pay as workers switch physical firms identify relative firm pay policies.

We now transpose the notion of a connected set to our firm-year FEs model. Identification of the firm-year FEs framework is obtained within connected sets, where connections are formed through worker mobility across firm-years. Physical firms switch identity each year, connected sets are defined by switches across firm-years, and repeat worker observations (including workers who stay at the same physical firm across years) constitute switches. Firm-year FEs within a connected set are relative to the FE of one normalized firm-year. Intuitively, changes in residual pay as workers switch firm-years identify relative firm-year pay policies.

Fig. 2 illustrates identification of connected sets in the firm-year FEs model with two periods (indexed $t = 1, 2$) and two firms (indexed A and B) with two employees each (shown as circles). If all workers stay at their original employer, as in panel (a), then two connected sets are formed, one around each physical firm over time. In contrast, if some workers switch across physical firms, as in panel (b), the connected set spans the set of firm-years connected through worker mobility. Since separate identification of worker and firm-year components of pay requires connectedness, we are looking for the largest set of firm-years and workers in a connected set such as that illustrated in panel (b) of Fig. 2. Note that this

¹² Subject to the caveat that the connected sets may differ in the two models. In practice, the difference in the connected sets across the two models is minor.

¹³ Further details and formal definitions of connectedness are contained in Appendix B.1.

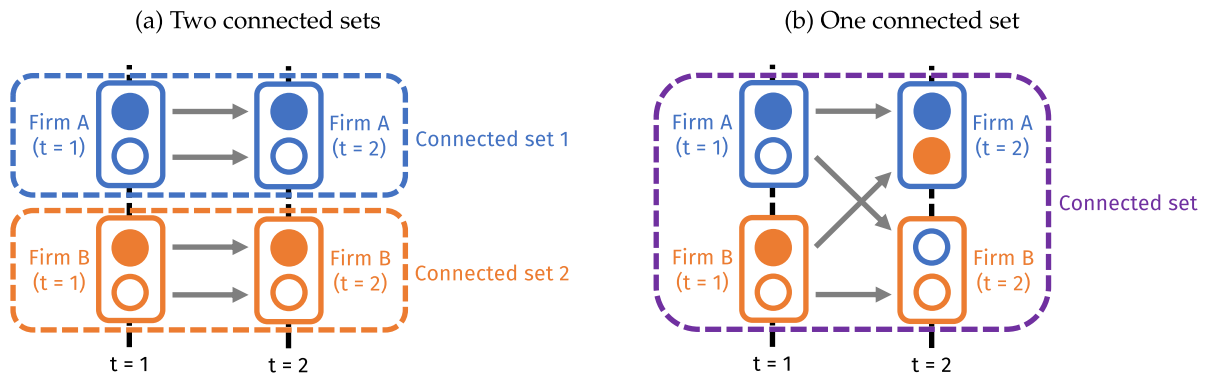

Fig. 2. Illustrating identification of the connected set(s) in the firm-year FE model. Note: Solid rectangles represent firm-years, with firm A in blue and firm B in orange. Solid and hollow circles represent workers, with worker 1 in solid blue, worker 2 in hollow blue, worker 3 in solid orange, and worker 4 in hollow orange. Vertical dashed lines represent time, with period $t = 1$ to the left and period $t = 2$ to the right. Solid arrows represent worker transitions across firm-years. Dashed rectangles represent the connected set(s) formed by worker transitions across firm-years.

notion of a connected set is a subtle extension of that in AKM after replacing “firm” in their framework with “firm-year” in our setting.¹⁴

Two qualifications are in order. First, because our later analysis partly relies on a leave-one-out bias correction due to KSS, which requires elimination of individual worker–firm matches in the data, we restrict our attention to the largest leave-one-out connected set. A leave-one-out connected set is a connected set that remains connected – so that the sample of workers and firms in the connected set does not change – after eliminating any worker–firm match among the leave-one-out connected set. Second, because the largest connected sets in general differ between the firm FE model and the firm-year FE model – although in practice the difference is minor – we restrict attention to the largest connected set in the firm-year FE model to be consistent when we compare models. It is straight-forward to see that the (leave-one-out) connected set of the firm-year FE model is a weak subset of that associated with the firm FE model.

Strict exogeneity. Analogous to the assumption made in the original AKM paper, we assume that ε_{ijt} satisfies a strict exogeneity condition:

$$\mathbb{E}[\varepsilon_{ijt} | i, jt, \mathbf{X}_{it}] = 0. \tag{3}$$

Extending the argument in Card et al. (2013) to our firm-year FE model, a key issue for identification based on the strict exogeneity condition (3) is whether the composite error term is orthogonal to the vector of firm-year identifiers in the matrix form of our wage Eq. (1). A sufficient condition for the latter to hold is that the assignment of workers across firms obeys a strict exogeneity condition with respect to ε_{ijt} , namely

$$\mathbb{P}[J(i, t) = j | \varepsilon_{ijt}] = \mathbb{P}[J(i, t) = j] \quad \forall i, t. \tag{4}$$

This assumption is consistent with worker mobility based on worker identity i and the identity of all firm-years jt in the economy. However, it rules out mobility based on ijt -specific match effects. This precludes endogenous mobility, defined as selection of some worker i into some firm j in year t based on the realization of the residual wage component ε_{ijt} in Eq. (1).

Condition (3) implicitly imposes restrictions on workers’ (potential) wages across firm-years. Taking conditional expectations subject to condition (3) in Eq. (1), worker i earns $\alpha_i + \psi_{jt} + \mathbf{X}_{it}\boldsymbol{\beta}$ on average when employed at firm j in year t and earns $\alpha_i + \psi_{j't'} + \mathbf{X}_{it'}\boldsymbol{\beta}$ on average when employed at firm $j' \neq j$ in year $t' > t$. Condition (3) also implies that worker i would have earned $\alpha_i + \psi_{jt} + \mathbf{X}_{it'}\boldsymbol{\beta}$ on average had they counterfactually remained employed at firm j in year t' . These assertions are closely related to parallel trends in the event study approach of Card et al. (2013) who estimate firm FE models on German administrative data. In our setting, a specific concern is that person FE models may drift in a way that is correlated with worker mobility across firm-years. Unfortunately, the same event study approach does not apply in the context of our firm-year FE model due to the instability of firm pay across years, which is the central feature of our empirical framework. Nevertheless, in Section 4.6 we address the specific concern that changes in unobserved worker heterogeneity over time may confound our measures of firm pay dynamics.

¹⁴ For the original AKM model with firm FE models, Card et al. (2013) provide a battery of specification checks, including an event study around workers moving between employers in different firm FE quantiles. While insightful in a firm FE context, where firm pay policies are assumed to be constant, such an event study design cannot be directly extended to our setting where, across two years, all workers are considered movers between firm-years.

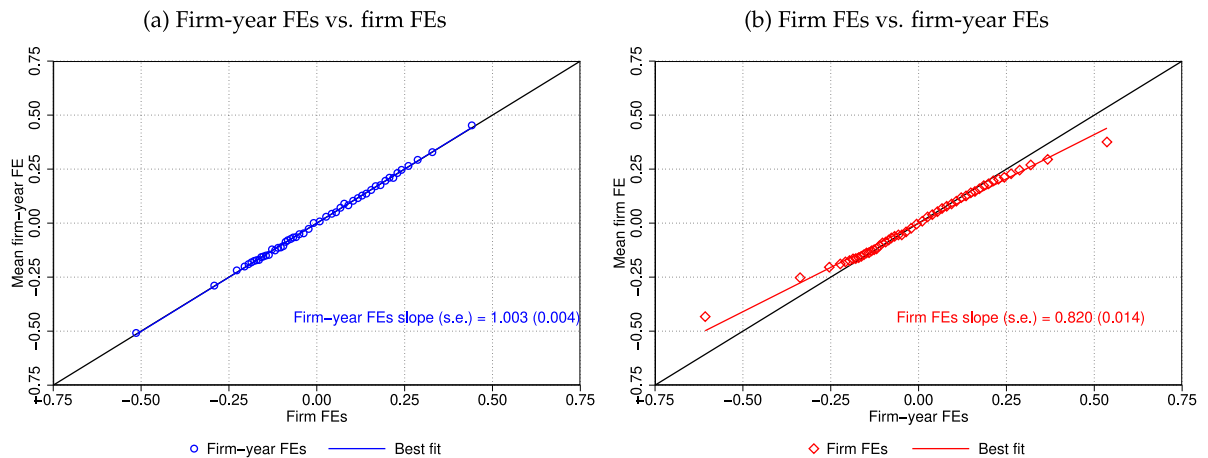

Fig. 3. Comparison between firm FEs and firm-year FEs. *Note:* Figure shows binned scatter plots of mean firm-year FEs against firm FEs (panel (a)) and of mean firm FEs against firm-year FEs (panel (b)). Solid black line shows 45-degree line, along which firm year FEs equal firm FEs. Linear best fit is shown as colored solid lines.

Source: LISA, LOUISE, and RAMS, 1985–2016.

4. Understanding firm pay dynamics

We now use the statistical framework from the previous section to study firm pay dynamics.

4.1. Cross-model comparison of conditional means and percentiles

A natural first question to ask is: To what extent do our estimated firm-year FEs align with a set of alternatively estimated firm FEs? To assess this, Fig. 3 plots conditional means of firm-year FEs against firm FEs and vice versa. Panel (a) shows the projection of firm-year FEs onto firm FEs in a binned scatter plot. The estimated coefficient is 1.003 with a standard error of 0.004, making the slope statistically indistinguishable from unity at conventional levels.¹⁵ This suggests that model misspecification due to the omission of firm-year FEs does not materially affect the estimated fixed component of firm pay, which is closely approximated by the mean firm-year FE. Notably, this result is similar to that in Lachowska et al. (2021) for the US state of Washington. However, the test in panel (a) is inconclusive with regards to whether or not firm-year FEs matter over and above firm FEs, since any variation in firm-year FEs around the constant firm FE is purged here.

Conversely, panel (b) of Fig. 3 shows the projection of firm FEs onto firm-year FEs in a binned scatter plot. Unlike in panel (a), we estimate a coefficient of 0.820 with a standard error of 0.014, which lies significantly below unity. Together with the previous result, this suggests that there is substantial temporary variation in firm-year FEs around the estimated fixed component of firm pay. The intuition behind this result is similar to the attenuation effect that other transitory variation in independent (but not in dependent) variables has on estimated regression coefficients, for example in the context of classical measurement error (Hausman, 2001).

In this context, the kind of transitory variation in firm-year FEs that these results suggest is not a bug but a feature of the exercise. Researchers may be interested precisely in transitory fluctuations in firm pay around a fixed level, for example due to (transitory or persistent) productivity shocks. In fact, in Section 4.3, we show that fluctuations in firm-year pay are significantly tied to variation in firm performance, specifically labor productivity (i.e., value added per worker). Additionally, in Section 4.4, we show that most of the extra variation contained in firm-year FEs is not accounted for by limited mobility bias.

4.2. Firm pay mobility

To shed further light on the nature of firm pay dynamics, Fig. 4 plots the autocorrelation of firm pay in year t with firm pay in year $t + \tau$, for $0 \leq \tau \leq 31$. Panel (a) shows the employment-unweighted autocorrelation for either an unbalanced panel of firms or a balanced panel of firms (i.e. restricting attention to firms in the sample for the entire 32-year period).

¹⁵ Note that we do not adjust standard errors to reflect first-stage estimation error. However, given the size of the data as well as the comparison between the plug-in variance versus KSS bias-corrected variance of our estimates shown below in Section 4.4, we suspect that such an adjustment would not materially affect our conclusions.

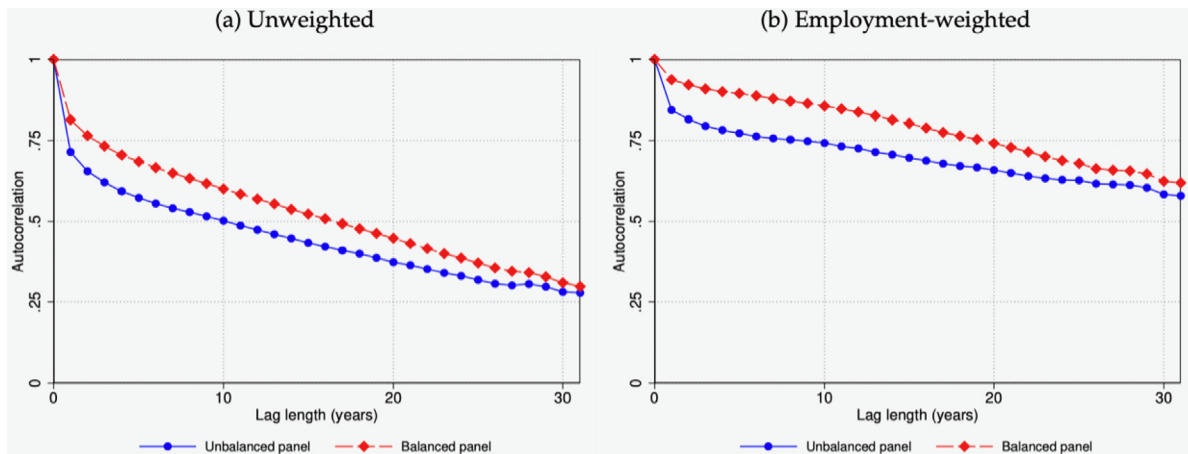

Fig. 4. Autocorrelation of firm-year FEs at various lag lengths. *Note:* Autocorrelation between firm pay in year t and firm pay in year $t + \tau$, where τ is the lag length in years and $0 \leq \tau \leq 31$. Panel (a): employment-unweighted autocorrelation for either all firms or a balanced panel of firms, i.e. those firms that remain in the sample for the entire 32-year period. Panel (b): employment-weighted autocorrelation for either all firms or a balanced set of firms. Weights correspond to average employment during the years the firm is active. The figure is constructed based on the underlying data in Tables C.1–C.4 collapsed across all initial years t with equal weight given to each year t . Source: LISA, LOUISE, and RAMS, 1985–2016.

Panel (b) repeats the analysis instead weighting by employment (using average employment during the years the firm is active). For visual clarity, Fig. 4 takes the (equally weighted) average across all initial years t .

Appendix C.1 provides the full set of autocorrelations and autocovariances by initial year t and subsequent year $t + \tau$ for the employment-weighted balanced panel, employment-weighted unbalanced panel, unweighted balanced panel and unweighted unbalanced panel. In the interest of space, we focus our discussion here on the employment-weighted balanced panel (Table C.1). The autocorrelation of firm pay dips between year t and $t + 1$, and subsequently declines at a close to proportional rate. These patterns are broadly consistent with firm pay being well approximated as the sum of a persistent AR1-process and a transitory i.i.d. process. We find an employment-weighted autocorrelation of firm pay in a balanced 13-year panel of Swedish firms of 0.82. For comparison, Lachowska et al. (2021) report a corresponding value of 0.74 using administrative data from the US state of Washington. That is, our measured persistence of firm pay is somewhat higher than what they find. The two numbers, however, are not directly comparable, as they require firms to be active at least 13 years while we require them to be active 32 years. In the unbalanced employment weighted panel, the 13 year autocorrelation is 0.71, which is just below their measure. Hence, our findings on the persistence of firm pay in Sweden are broadly similar to those from the US state of Washington.

The persistence of firm pay is lower in the unweighted panel, indicating that employment is concentrated among firms who change pay by relatively less. Whether the unweighted or weighted autocorrelation is more relevant depends on whether a researcher takes a firm or worker level perspective. In any case, the fact that the autocorrelation continues to decline at a close to proportional rate over 31 years indicates that firm pay truly is dynamic, in the sense that it does not appear to have a perfectly persistent component. We also note based on the autocovariances in Table C.1 in Appendix C.1 that firm pay dynamics appear to be non-stationary over this period, in the sense that the diagonal terms are increasing over time (we discuss this further in the next section).

4.3. What are the drivers of firm pay dynamics?

To what extent is firm pay tied to economically meaningful markers of firm performance? To address this question, we combine our estimates of firm pay dynamics from 1985–2016 with rich data on firm financials for the near-universe of Swedish firms starting in 1997.

Specifically, we estimate the following second-stage equation:

$$\widehat{\psi}_{jt} = \mathbf{Z}_{jt} \boldsymbol{\gamma} + v_{jt}, \tag{5}$$

where $\widehat{\psi}_{jt}$ are the estimated firm-year FEs, \mathbf{Z}_{jt} is a vector of firm characteristics with loading vector $\boldsymbol{\gamma}$, and v_{jt} is an error term. We consider as independent variables \mathbf{Z}_{jt} in (5) capital, firm size (i.e., the number of workers), and labor productivity, all in logs. We anchor our choice of independent variables in common firm dynamics models, which predict that these measures are key determinants of a firm's marginal product of labor and – to the extent that firms pass on some of their marginal product of labor to workers' remuneration – firm pay. We consider versions of (5) in both levels and one, three, five and 10 year within-firm differences. All specifications control for year FEs and two-way clustered standard errors by

Table 2

Relating firm pay to firm fundamentals.

Source: LISA, LOUISE, RAMS, and FEK, 1997–2016.

	Univariate					Multivariate				
	Level	1-year	3-year	5-year	10-year	Level	1-year	3-year	5-year	10-year
Log capital	0.037 (0.002)	0.020 (0.002)	0.030 (0.003)	0.032 (0.003)	0.037 (0.006)	0.052 (0.003)	0.020 (0.004)	0.024 (0.002)	0.027 (0.003)	0.045 (0.008)
Log number of workers	0.026 (0.003)	−0.007 (0.006)	0.017 (0.005)	0.016 (0.005)	0.006 (0.007)	−0.031 (0.003)	−0.015 (0.007)	0.005 (0.005)	0.001 (0.005)	−0.021 (0.008)
Log value added per worker	0.140 (0.009)	0.025 (0.005)	0.038 (0.005)	0.046 (0.006)	0.070 (0.010)	0.070 (0.005)	0.021 (0.005)	0.034 (0.004)	0.040 (0.006)	0.056 (0.008)
R^2						0.256	0.004	0.011	0.017	0.039
Firm-years	1,203,530	1,005,640	751,099	568,995	266,726	1,203,530	1,005,640	751,099	568,995	266,726

Note: Univariate and multivariate regression results based on equation (5). The univariate results show the regression coefficient and standard error in parentheses for one independent variable at a time. The multivariate results show the regression coefficients when all independent variables are included in a joint regression. The column labeled “level” shows results when both the dependent and independent variables are contemporaneous. The remaining columns labeled “N-year,” for $N = 1, 3, 5, 10$, show the N-year within-firm difference in the dependent variable on N-year within-firm difference in the independent variable. For the difference specifications, the independent variables are winsorized below the 5th percentile and above the 95th percentile. All specifications control for year FEs. Firm-year FEs are estimated in the pooled 1985–2016 sample. Standard errors in parentheses are two-way clustered by firm and year. Standard errors are not adjusted to reflect first-stage estimation error. Regressions are weighted by average firm employment across the years in which a firm is active.

firm and year.¹⁶ To deal with outliers in the difference specifications, we winsorize the bottom and top five percent of firm-years sorted by the relevant independent variable.¹⁷ Finally, we weigh firm-years by a firm’s average employment during the years when it is active.

The first part of Table 2 shows results from univariate regressions. The first five columns of Table 2 present results from univariate regressions. Firms with a higher capital stock, more employees, and greater labor productivity pay more. The univariate estimates in levels imply that a firm with one percent more capital pays 0.037 percent more, a one percent larger firm pays 0.026 percent more, and a one percent more productive firm pays 0.140 percent more.

Turning to the within-firm variation as captured by the univariate estimates in differences, a firm that increases its capital stock by one percent year-on-year raises pay by 0.020 percent, a firm that grows by one percent reduces pay by 0.007 percent, and a firm that becomes one percent more productive pays 0.025 percent more. As the lag length grows, the point estimates on changes in capital and labor productivity rise, while that on firm size is non-monotone but always relatively close to zero. The strengthening relationship between changes in firm pay and labor productivity as the horizon lengthens is consistent with the presence of either measurement error in labor productivity or otherwise temporary fluctuations that are not passed on to pay to the same extent as permanent or persistent changes.

The second part of Table 2 shows results from multivariate regressions, controlling simultaneously for the levels of or changes in capital, firm size, and labor productivity. The estimate in levels for the effect of capital on pay is larger when controlling for firm size and labor productivity compared to the univariate estimate, consistent with capital, all else equal, increasing a firm’s marginal product of labor and thus firm pay. Firm size, all else equal, reduces a firm’s marginal product of labor and hence pay, consistent with decreasing returns to labor inputs in production. Finally, labor productivity is positively associated with pay, with the point estimate implying that a one percent more productive firm pays around 0.070 percent more, holding capital and firm size fixed.

Turning to within-firm changes as captured by the multivariate estimates in differences, firms raise pay as they accumulate capital, controlling for changes in firm size and labor productivity. This pattern gradually strengthens as the lag length increases from one to ten years—the point estimate on the 10-year difference is 0.045 compared to an estimate of 0.052 in levels. In contrast, the point estimate for changes in firm size, controlling for changes in capital and labor productivity, is either negative or not statistically different from zero. Finally, the relationship between changes in labor productivity and firm pay, controlling for changes in capital and firm size, gradually strengthens as the lag length increases from one to ten years—the point estimate on the 10-year difference is 0.056 compared to an estimate of 0.070 in levels. These patterns are consistent with firms sharing some of their higher labor productivity with workers or, alternatively, firms paying more to induce higher effort by workers, leading to higher productivity.

To further analyze the correlation between productivity and firm pay, we estimate a distributed lag framework of firm pay on productivity including up to 10 years of lagged productivity, current productivity, and four years of future

¹⁶ Note that we do not adjust standard errors to reflect first-stage estimation error. However, given the size of the data as well as the comparison between the plug-in variance versus KSS bias-corrected variance of our estimates shown below in Section 4.4, we suspect that such an adjustment would not materially affect our conclusions.

¹⁷ The results without winsorization shown in Appendix C.2 are qualitatively the same but quantitatively somewhat less pronounced.

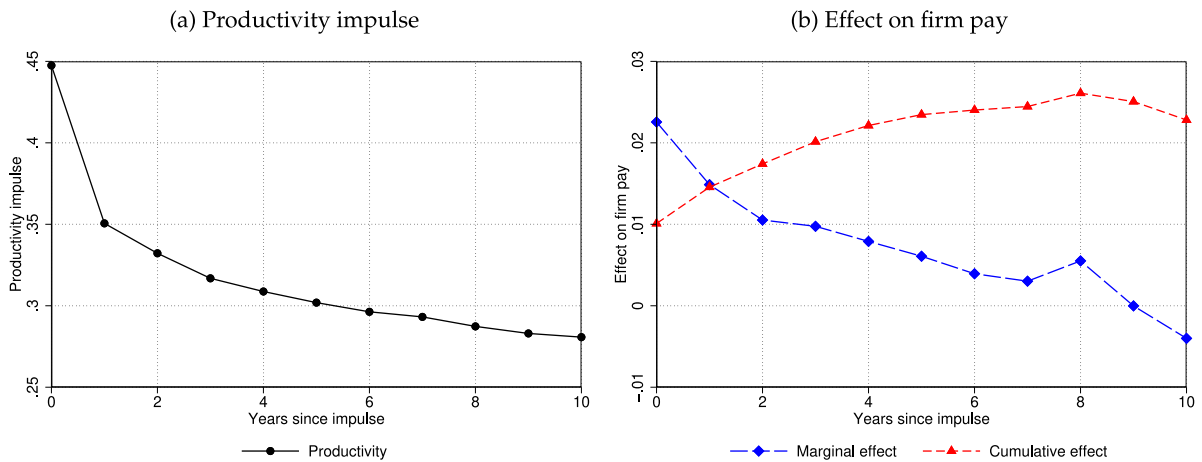

Fig. 5. Effect of productivity impulse on firm pay. *Note:* Estimated impulse response of firm pay to a one-standard deviation change in log value added per worker at time 0 that dissipates as in the data. Panel (a) shows the estimated process for productivity, which we compute as log value added per worker in the data. Panel (b) shows the resulting estimated process for firm pay. “Marginal effect” is the estimated elasticity of firm pay in year t to log value added per worker in year 0. “Cumulative effect” is estimated firm pay in year t in response to a one standard deviation increase in log value added per worker in year 0 that dissipates as in the data. *Source:* LISA, LOUISE, RAMS, and FEK, 1997–2016.

productivity, controlling for firm and year FEs:

$$\hat{\psi}_{jt} = \alpha + \sum_{l=-10}^4 \zeta_l VAPW_{j,t+l} + v_{jt}, \tag{6}$$

where $\hat{\psi}_{jt}$ are the estimated firm-year FEs in year t based on Eq. (1), α is a constant, $VAPW_{j,t+l}$ is log value added per worker in year $t + l$ with corresponding loading ζ_l , for $l = -10, \dots, 4$, and v_{jt} is an error term.

After estimating Eq. (6), we use the estimated lagged coefficients on productivity together with the empirical autocorrelation of productivity to predict the dynamic impact of a one standard deviation shock to productivity on firm pay. To be clear, we use the word “impact” even though our estimates should not be interpreted as causal—they simply reflect the dynamic correlation between firm pay and productivity.

Fig. 5 plots the results from this exercise. Panel (a) shows the shock process we feed in to productivity—a one standard deviation, or around 45 log points, increase in value added per worker at time 0 that subsequently dissipates as in the data. Productivity is persistent, with a half life of over 10 years, mirroring the high persistence of firm pay that we documented in Section 4.2.

Panel (b) plots the estimated coefficients on the lags of productivity in as a solid line with circles in blue. We label this as the marginal impact of productivity in year 0 on firm pay in year t , since it reflects the estimated impact holding fixed productivity in all other years. The increase in productivity raises pay up to eight years after the shock, holding fixed subsequent productivity, indicating that even if the increase in productivity is fully transitory, the impact on pay is persistent. Of course, productivity is persistent in the data. The dashed line with diamonds in red shows the cumulative impact of a one standard deviation change in productivity at time zero on firm pay, taking into account the fact that the change in productivity only dissipates slowly. A one standard deviation increase in productivity at time 0 that dissipates as in the data is associated with 2.5 log points higher firm pay eight years after the initial increase in productivity. Given that the estimated variance of firm-year FEs is 4.2 log points (see Table 3), this represents a substantial increase in firm pay relative to the population distribution.

Taken together, the results of this exercise demonstrate that changes in firm fundamentals are associated with quantitatively meaningful and persistent changes in firm pay dynamics.

4.4. Variance decompositions

Extending the firm FE approach used by a large strand of the literature to our setting with firm-year FEs, we decompose the variance of log earnings (y_{ijt}) based on the estimating equation (1) into components due to permanent worker pay heterogeneity (α_i), time-varying firm pay heterogeneity (ψ_{jt}), their covariance, and other terms:¹⁸

$$\text{Var}(y_{ijt}) = \text{Var}(\hat{\alpha}_i) + \text{Var}(\hat{\psi}_{jt}) + 2 \times \text{Cov}(\hat{\alpha}_i, \hat{\psi}_{jt}) + 2 \times \sum \text{Cov}(\cdot, \cdot) + \text{Var}(\hat{\epsilon}_{ijt}), \tag{7}$$

¹⁸ See also Card et al. (2013, 2016), Alvarez et al. (2018), Sorkin (2018), and Song et al. (2018).

Table 3
 Variance decomposition based on firm FEs vs. firm-year FEs.
 Source: LISA, LOUISE, and RAMS, 1985–2016.

	Plug-in estimates		KSS bias-corrected estimates	
	Firm FEs	Firm-year FEs	Firm FEs	Firm-year FEs
<i>Panel A. AKM variance decomposition</i>				
Var(y_{ijt})	0.268	0.268	0.268	0.268
(% of total)	(100.0%)	(100.0%)	(100.0%)	(100.0%)
Var($\hat{\alpha}_i$)	0.095	0.096	0.079	0.085
(% of total)	(35.6%)	(35.9%)	(29.6%)	(31.8%)
Var($\hat{\psi}_{jt}$)	0.034	0.042	0.032	0.038
(% of total)	(12.7%)	(15.9%)	(12.1%)	(14.4%)
2*Cov($\hat{\alpha}_i, \hat{\psi}_{jt}$)	0.004	0.003	0.005	0.004
(% of total)	(1.6%)	(1.1%)	(1.9%)	(1.3%)
<i>Panel B. Descriptive statistics</i>				
Corr($\hat{\alpha}_i, \hat{\psi}_{jt}$)	0.075	0.044	0.100	0.062
Worker-years (% of population)	90,909,217 (77.0%)	90,909,217 (77.0%)	90,909,217 (77.0%)	90,909,217 (77.0%)
Firm-years (% of population)	2,170,667 (33.8%)	2,170,667 (33.8%)	2,170,667 (33.8%)	2,170,667 (33.8%)
Unique workers (% of population)	5,967,674 (74.6%)	5,967,674 (74.6%)	5,967,674 (74.6%)	5,967,674 (74.6%)
Unique firms (% of population)	278,824 (31.6%)	278,824 (31.6%)	278,824 (31.6%)	278,824 (31.6%)

Note: The variance decomposition is based on earnings equation (7): $y_{ijt} = \alpha_i + \psi_{jt} + \mathbf{X}_{it}\beta + \varepsilon_{ijt}$. The specification contains either firm FEs (ψ_j) or firm-year FEs (ψ_{jt}). For notational convenience, both specifications denote by ψ_{jt} the relevant set of FEs. The resulting variance decomposition is $\text{Var}(y_{ijt}) = \text{Var}(\hat{\alpha}_i) + \text{Var}(\hat{\psi}_{jt}) + 2 \times \text{Cov}(\hat{\alpha}_i, \hat{\psi}_{jt}) + 2 \sum \text{Cov}(\cdot, \cdot) + \text{Var}(\hat{\varepsilon}_{ijt})$. The largest connected set is stated in terms of the fraction of worker-years. Both the firm and firm-year models are estimated in the largest connected set under the firm-year FEs model. The KSS bias-corrected estimates are based on the same leave-one-out connected set after removing singleton worker observations.

where $\text{Var}(\cdot)$ denotes the variance operator, \hat{X} denotes the estimate of some variable X , and $\text{Cov}(\cdot, \cdot)$ represents the remaining variances and covariances.¹⁹

A challenge in estimating the variance components in Eq. (7) above is that the underlying FEs α_i and ψ_{jt} are estimated with noise when working with finite data—more specifically, a finite number of workers switching across firms in the firm FEs model due to AKM, or across firm-years in our firm-year FEs model. The reason for this is that, while AKM show that estimates of α_i and ψ_{jt} are unbiased under the usual conditions, nonlinear transformations of the estimates are generally biased. Intuitively, a linear transformation (e.g., the mean) of mean-zero error realizations cancel out in expectations, while nonlinear transformations (e.g., the variance) of mean-zero error realizations do not. In the literature, this incidental parameter problem is commonly referred to as “limited-mobility bias” (Abowd et al., 2004; Andrews et al., 2008, 2012; Bonhomme et al., 2021). To get around limited-mobility bias, we implement the recently developed “leave-one-out” bias correction by KSS. Their framework delivers unbiased and consistent estimates of the variance components akin to those in Eq. (7) while allowing unrestricted patterns of heteroskedasticity in the error term ε_{ijt} —see KSS and Lachowska et al. (2021) for details of their econometric procedure.

Table 3 presents results from the decomposition in Eq. (7) under both the standard plug-in estimates and the KSS bias-corrected estimates. As noted above, to be consistent across models both the firm FEs and firm-year FEs models are estimated in the largest connected set under the firm-year FEs model. Consistent with typical findings in the literature, in an accounting sense worker FEs is the single most important factor behind earnings dispersion. Across specifications – firm or firm-year FEs under either the plug-in method or the KSS bias correction method – worker FEs account for 8–10 log points or 30–36 percent of dispersion in log earnings.

Firm FEs account for just over 3 log points or around 12–13 percent of earnings dispersion. Allowing firm pay to vary over time by considering firm-year FEs increases the variance of pay due to time-varying firm pay to around 4 log points or around 14–16 percent of overall earnings dispersion. That is, letting firm pay vary flexibly between years raises the share of earnings dispersion due to firms by roughly 19–24 percent. Of course, it is not surprising per se that allowing for greater flexibility in the firm FEs will raise the estimated importance of firms. Yet we view the increase in the explanatory power of firms as large enough to warrant a further investigation of firm pay dynamics.

¹⁹ Specifically, the term $\sum \text{Cov}(\cdot, \cdot)$ consists of the sum of (co-)variances $\hat{\beta}' \text{Cov}(\mathbf{X}_{it}) \hat{\beta} / 2$, the sum of covariances between $\hat{\alpha}_i$ and each entry in \mathbf{X}_{it} , and the sum of covariances between $\hat{\psi}_{jt}$ and each entry in \mathbf{X}_{it} . It is worth noting that our KSS bias correction does not provide bias-corrected estimates of any terms contained in $\sum \text{Cov}(\cdot, \cdot)$. For this reason, these additional terms are omitted from the variance decomposition below.

Table 4
 Variance of the firm FEs versus firm-year FEs at various panel lengths.
 Source: LISA, LOUISE, and RAMS, 1985–2016.

	2 years		4 years		8 years		16 years		32 years
	1985–1986	2015–2016	1985–1988	2013–2016	1985–1992	2009–2016	1985–2000	2001–2016	1985–2016
<i>Panel A. Plug-in estimates</i>									
Var($\hat{\psi}_j$)	0.036	0.056	0.026	0.046	0.023	0.042	0.033	0.040	0.034
Var($\hat{\psi}_{jt}$)	0.037	0.058	0.029	0.050	0.029	0.048	0.041	0.048	0.042
Difference (%)	3.0	3.2	12.3	8.0	27.2	13.5	22.3	19.2	25.2
<i>Panel B. KSS bias-corrected estimates</i>									
Var($\hat{\psi}_j$)	0.023	0.037	0.020	0.037	0.019	0.038	0.031	0.038	0.032
Var($\hat{\psi}_{jt}$)	0.023	0.037	0.022	0.039	0.024	0.041	0.036	0.043	0.038
Difference (%)	3.0	1.8	12.3	5.0	26.0	8.9	17.8	13.5	19.0
<i>Panel C. Descriptive statistics</i>									
Firm-years	82,105	129,774	272,750	375,728	634,671	776,266	1,247,529	1,436,452	2,170,667
Unique firms	47,138	71,885	93,990	120,259	144,145	161,399	203,704	214,284	278,824

Note: The variance decomposition is based on earnings equation (7): $y_{ijt} = \alpha_i + \psi_{jt} + \mathbf{X}_{it}\beta + \varepsilon_{ijt}$. The resulting variance decomposition is $\text{Var}(y_{ijt}) = \text{Var}(\hat{\alpha}_i) + \text{Var}(\hat{\psi}_{jt}) + 2 \times \text{Cov}(\hat{\alpha}_i, \hat{\psi}_{jt}) + 2 \sum \text{Cov}(\cdot, \cdot) + \text{Var}(\hat{\varepsilon}_{ijt})$. Both the firm and firm-year models are estimated in the largest connected set under the firm-year FEs model. The KSS bias-corrected estimates are based on the same leave-one-out connected set after removing singleton worker observations. Earnings have been demeaned in each year to remove any aggregate time trends.

For comparison, the covariance term remains small across all specifications, accounting for around 1–2 percent of earnings dispersion. Although the estimated correlation between worker and firm FEs remains positive, it falls from 8–10 percent in the firm FEs specifications to 4–6 percent in the firm-year FEs specifications.

Consistent with the argument that the plug-in estimates are inflated in the presence of limited mobility, the variance of firm FEs and firm-year FEs falls as we move from the plug-in estimates to the KSS bias correction. The decrease is, however, relatively modest, from around 3.4 log points to 3.2 log points for the firm FEs model and from around 4.2 log points to around 3.8 log points for the firm-year FEs model. If anything, the variance of the worker FEs declines significantly as we apply the KSS bias correction. The covariance between worker and firm FEs also rises with the KSS bias correction, but the increase is relatively modest. We take these patterns as indicative that our panel of Swedish data is sufficiently long and connected to yield relatively small bias from limited mobility with the plug-in estimates.

4.5. Variance decompositions revisited: The role of the time horizon

In contemporaneous work, Lachowska et al. (2021) estimate a similar firm-year FEs AKM model as we do using linked employer–employee data from the US state of Washington for 2002–2014. They argue that the improvement in the statistical contribution of firms to overall earnings dispersion when allowing firm FEs to vary over time is relatively minor. Although our two complementary studies differ in several aspects – they study the US state of Washington and we study Sweden, we use average monthly earnings while they use either quarterly income or hourly pay, etc. – we believe that an important difference is the length of the panel. In particular, they use 13 years of data while we use 32 years of data. It is natural to expect a larger deviation between the firm FEs model and the firm-year FEs model as the length of the panel increases.

To assess this hypothesis, Table 4 shows results from the firm FEs model and the firm-year FEs model as the length of the panel increases. We present estimates under both the plug-in method (panel A) and KSS bias-corrected estimates (panel B). The variance of firm FEs and firm-year FEs aligns closely in a 2-year panel, deviating by 2–3 percent. Already in a 4-year panel, however, the deviation is in the range of 5–12 percent, with the exact number depending on the time period and specification. In an 8-year panel, the deviation between firm FEs and firm-year FEs is around 9–27, while that in a 16-year panel is around 14–22 percent. In our complete sample of 32 years, the discrepancy between the two models settles at around 19–25 percent.

As noted above, it is not surprising that the variance of firm-year FEs is greater than that of firm FEs. Moreover, it is natural that the variance of firm-year FEs relative to firm FEs rises as the length of the panel increases. The key question is how much greater the variance of firm-year FEs is and how quickly the divergence relative to the firm FEs model appears. Our results suggest that the assumption of fixed firm pay may be “good enough” in a two-year panel, but less appropriate when the length of the panel exceeds eight years.

In light of this finding, an alternative would be to estimate the firm FEs model in overlapping subperiods of length shorter than eight years. We stress, however, that by pooling data from many years, measurement error is presumably lower in the firm-year FEs. Moreover, for some applications – some of which we highlight further below – it is very useful to allow for year-to-year fluctuations in firm pay.

Table 5
Stability of firm-year FEs across models.
Source: LISA, LOUISE, and RAMS, 1985–2016.

	Levels	Differences
$\hat{\eta}$	0.946 (0.004)	0.843 (0.004)
Correlation	0.915	0.846

Note: Projection of firm-year FEs estimated in four 8-year subperiods (1985–1992, 1993–2000, 2001–2008, 2009–2016) on the firm-year FEs estimated on the pooled 1985–2016 sample, as specified in Eq. (8). All specifications control for year FEs and are weighted by employment, with standard errors clustered at the firm level.

4.6. Time-varying firm heterogeneity or time-varying worker heterogeneity?

Our firm-year FEs model represents a generalization of the workhorse econometric framework due to AKM in that we allow firm pay policies to vary freely each period. At the same time, our specification continues to restrict unobserved worker heterogeneity. Clearly, allowing unobserved worker heterogeneity to vary freely each period is not sensible since such a model would be fully saturated (i.e., worker-year FEs would account for all of the empirical wage variation). Therefore, some constraint on unobserved worker heterogeneity is necessary.

As in AKM, the specific restriction that we impose on unobserved worker heterogeneity is that it is permanent.²⁰ To the extent that worker heterogeneity is not permanent but persistent, the assumption that it is fixed may be a reasonable approximation, at least in short panels. Over longer time horizons, however, it is possible that our measures of firm pay dynamics under this restriction conflate time-varying unobserved worker heterogeneity with true firm pay dynamics. That is, time-varying worker heterogeneity could be a threat to identification of firm-year FEs to the extent that workers on similar trajectories in terms of their unobserved heterogeneity sort into the same firms.

To assess the consequence of our assumption of permanent worker heterogeneity for our estimates of firm pay dynamics, we first estimate our firm-year FEs model on the full period of 32 years of Swedish data from 1985–2016. Second, we run separate estimations of our firm-year FEs model in four 8-year subperiods (1985–1992, 1993–2000, 2001–2008, and 2009–2016). Finally, by projecting estimates from one model onto those from the other, we compare the two sets of normalized estimates—those using four separate 8-year subperiods and those using the complete 32-year panel:²¹

$$\hat{\psi}_{jt}^{\text{short}} = \eta \hat{\psi}_{jt}^{\text{long}} + \delta_t + v_{jt}, \tag{8}$$

where $\hat{\psi}_{jt}^{\text{short}}$ denotes the estimated firm-year FE from the 8-year subperiods, $\hat{\psi}_{jt}^{\text{long}}$ denotes the estimated firm-year FE from the full 32-year panel, δ_t denotes a year FE, and v_{jt} is an error term. In estimating Eq. (8), our interest lies in estimates of the coefficient η , which we would expect to be unity if the estimates from the two models were identical. In computing this estimate, we cluster standard errors at the firm level. In addition to estimating the regression Eq. (8), we also compute the correlation between the two firm-year pay estimates, after normalizing each set of estimates by partialing out year effects from each series. This analysis allows us to assess the stability of our firm-year FEs estimates across models that either hold individual heterogeneity constant or allow individual heterogeneity to vary over time.

Our findings in Table 5 suggest that the two sets of firm-year FEs estimates exhibit considerable stability across models. In a regression of the subperiod firm-year FEs on the full panel firm-year FEs in levels (column 1), we estimate a regression coefficient of 0.946 with a standard error of 0.004. Therefore, while the coefficient is statistically significantly below unity – indicating that the estimates from the two models are not identical – the two are closely linked. In line with this conclusion, the correlation between the two sets of estimates is 0.915, again suggesting that the two sets of estimates line up closely.

Estimating Eq. (8) in differences rather than levels is, perhaps, a stronger test of the sensitivity of the estimated firm-year FE to the assumption that worker unobserved heterogeneity is fixed. The results in differences (column 2) yield a regression coefficient of 0.843 with a standard error of 0.004. While below the estimate in levels, the point estimate continues to suggest that the two sets of estimates are strongly related. Again in line with this conclusion, the correlation between the two sets of estimates in differences is 0.846. We conclude from this analysis that our estimates of firm-year FEs are not substantially affected by allowing for unobserved worker heterogeneity to change over time.

5. Using the firm-year FEs model to understand changes in Swedish earnings inequality

In this last section of the paper, we use our estimated firm-year FEs model to shed light on changes in earnings inequality in relation to firm pay dynamics in Sweden between 1985 and 2016.

²⁰ This is in addition to controlling for flexible age profiles for each gender-education group.

²¹ For the year 2000, we retain the estimates from the second time window (1993–2000), although we have experimented with alternative arrangements without substantially affecting our results.

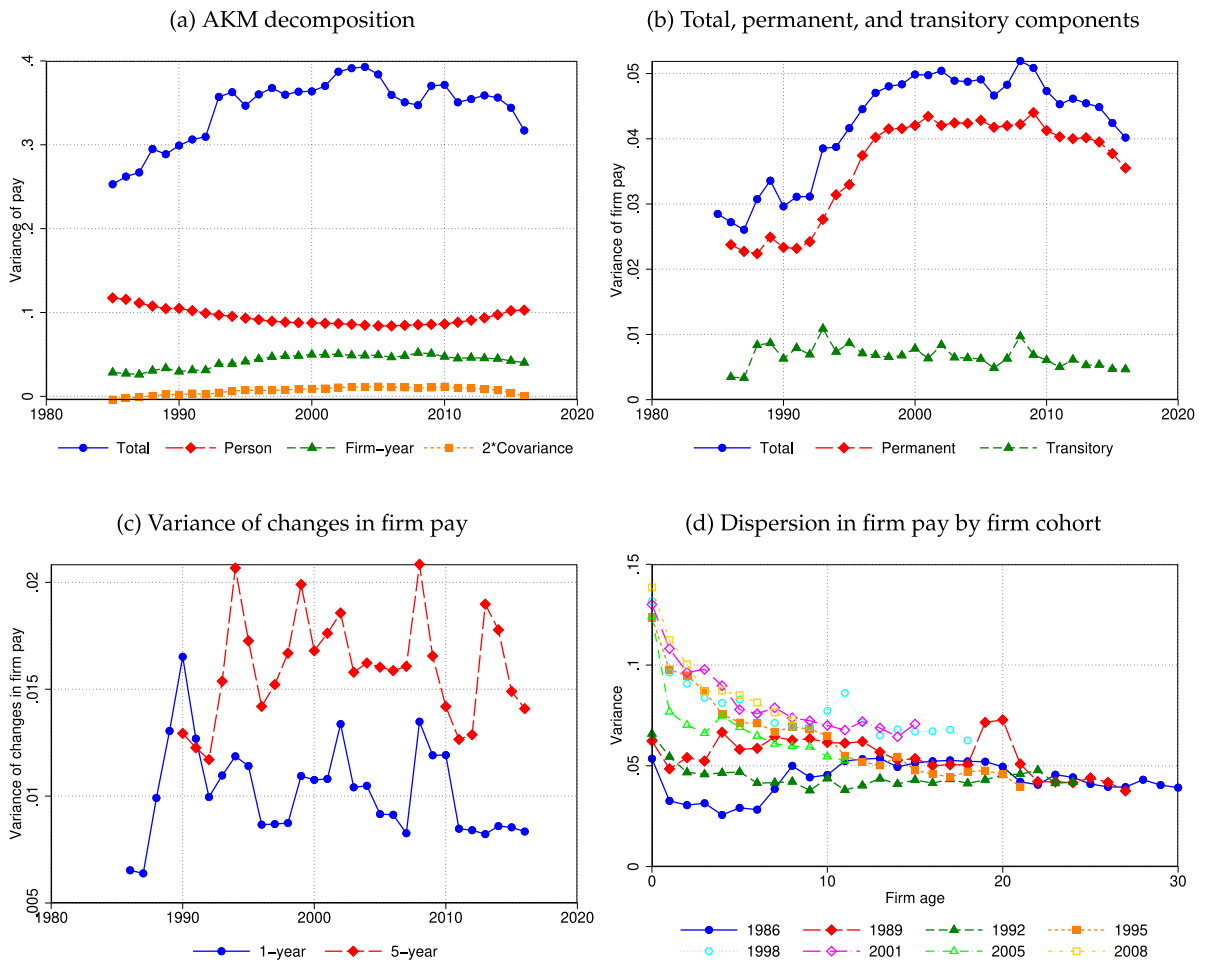

Fig. 6. Changes in firm pay dispersion over time. *Note:* Panel (a) plots the AKM variance decomposition over time. Panel (b) plots the first annual autocovariance of firm-year FEs (*permanent* component) and the difference between the overall variance of firm-year FEs and the permanent component (*transitory* component). Panel (c) plots the variance of one-year and five-year differences in firm-year FEs. Panel (d) plots the variance of firm-year FEs by firm age and year of entry. All panels use the plug-in method and weigh by employment. *Source:* LISA, LOUISE, and RAMS, 1985–2016.

5.1. Firm pay dynamics over time

Panel (a) of Fig. 6 decomposes the variance of log earnings based on our firm-year FEs model. As noted earlier, Sweden has experienced an increase in earnings inequality over this period. This increase is reflected in a modest rise in the variance of worker FEs, which – given that worker FEs are assumed to remain fixed over this period – is driven by entry and exit of workers.²² The variance of firm-year FEs rises from about 0.030 in 1985 to about 0.045 in the 2016, while two times the covariance between worker and firm-year FEs rises from around 0.000 to around 0.010 before falling again. The remainder of the increase in earnings dispersion is accounted for by observable worker characteristics (i.e., age, education, and gender) as well as the remaining covariance terms and the residual.

Naturally, one may be concerned that by not allowing worker FEs to change over time, our estimation forces the overall increase in inequality over this period to load on the firm-year FEs. Two observations lead us to believe that this is of less

²² The U-shaped pattern of the variance of worker FEs likely arises because a worker in the early or late part of a period on average spends fewer years in the sample due to left and right-censoring. To see this, consider a 3-year sample consisting of 3 young workers who each turns 20 in one of the 3 years, i.e. one new worker enters the sample in each year, and 3 old workers who each turns 59 in one of the 3 years, i.e. one of them exits the sample in each year. The first year contains 1 young worker with 3 years in the sample and 3 old workers with 1, 2 and 3 years in the sample, respectively. The last year contains 3 young workers with 1, 2 and 3 years in the sample, respectively, and 1 old worker with 3 years in the sample. The middle year contains 2 young workers with 2 and 3 years in the sample, respectively, and 2 old workers with 2 and 3 years in the sample, respectively. Hence, the average number of years an observation spends in the sample is $(1 + 2 + 3 + 3)/4 = 2.25$ in the first and last year, but $(2 + 2 + 3 + 3)/4 = 2.5$ in the middle year. Consequently, in the presence of measurement error or temporary variation in pay, we expect the worker FEs to have a lower variance in the middle year, since it averages over more years of observation for the average worker.

concern. First, our framework includes separate age controls by education and gender, allowing for differential paths of life-cycle wage growth by demographic groups. Hence, we are not assuming that pay, in expectation, remains fixed as a worker ages. Second, we argued in Section 4.6 that the estimated firm-year FEs in the pooled 1985–2016 population line up closely with those obtained in 8-year subperiods. In this sense, allowing worker FEs to change does not seem to much impact our estimated firm-year FEs. We further corroborate this point in Appendix D by showing that the estimated increase in the variance of firm-year FEs over this period is of similar magnitude if we instead estimate the model in subperiods, hence letting worker FEs vary over time.

5.2. Dissecting the increase in firm pay dispersion

The increase in firm pay dispersion over time in panel (a) could be accounted for by greater dispersion in firm pay changes over time, a higher persistence of changes to firm pay, or greater dispersion in firm pay upon entry. By allowing firm pay to change over time, our framework offers the opportunity to differentiate across these alternative hypothesis.

In order to assess the drivers of increasing cross-sectional dispersion in firm pay over time, panel (b) decomposes firm pay dispersion into a permanent and transitory part. We define the permanent component as the first annual autocovariance of firm pay, and the transitory component as the difference between overall cross-sectional variance in firm pay and the permanent component. This back-of-the-envelope decomposition is motivated by a view that firm pay has a permanent and transitory component, $\psi_{jt} = \nu_j + \varepsilon_{jt}$. Based on this simple decomposition, the increase in firm pay dispersion appears to be permanent in nature. In contrast, the variance of the transitory component has – after an initial increase in the late 1980s – declined.

Panel (c) contains an alternative look at changes in firm pay dynamics. Specifically, it plots the variance of the one-year and the five-year innovation to firm pay over time. Consistent with the lack of an increase in the temporary component in panel (b), there is no evidence of an increase in the variance to one-year innovations to firm pay. In fact, if anything there is some weak support for the notion that one-year volatility in firm pay has declined over this period. The variance of five-year innovations is higher than that of one-year innovations, consistent with the presence of a persistent component of firm pay that gradually builds up over time. There is not much evidence of an increase in the variance of five-year innovations over time. Yet due to the decline in the variance of the one-year innovations, the gap between the variance of the five-year and one-year innovations has risen over time. This is suggestive of a higher persistence of changes over time. Consistent with this conjecture, Appendix D.2 finds that the autocorrelation of firm pay has indeed risen over time.

In addition to a rise in the persistence of firm pay changes, there is also evidence that firm pay dispersion is higher already at firm entry in more recent years relative to 30 years ago, as illustrated by panel (d). Specifically, the figure plots the cross-sectional variance of firm pay by firm age and firm year of birth, offering two main take-aways. First, dispersion in firm pay tends to decline as a cohort of firms ages. Second, more recent cohorts of firms are more unequal at each point over their life cycle. Indeed, this higher entry inequality appears to be an important driver of the overall increasing cross-sectional dispersion in firm pay over this period.

To summarize, our firm-year FEs model allows us to link changes in earnings inequality to firm pay dynamics in Sweden. Without a dynamic framework for firm pay, it is impossible to analyze changes in firm pay over time or over the firm life cycle.

6. Conclusion

A key assumption that underlies a large literature building on the seminal two-way FEs framework by AKM is that firm pay policies are fixed. In this paper, we relax this assumption by proposing and estimating a model of firm pay dynamics featuring firm-year FEs, which accounts for idiosyncratically time-varying firm pay policies. An application of the firm-year FEs framework sheds new light on the drivers of increasing dispersion in firm pay in Sweden.

We use our expanded framework to document that firm pay heterogeneity is persistent, but not permanent, with an autocorrelation of firm pay over 10 years of around 0.75. At the same time, firm pay does change over time. Moreover, the nature of changes in firm pay in response to changes in firm fundamentals is consistent with predictions of benchmark firm dynamics models. For instance, firms that become more productive raise pay. In terms of understanding inequality, allowing for fluctuations in firm pay implies a roughly 25 percent greater role for firms in overall inequality, relative to a model that restricts firm pay policies to be constant. We find that the difference between a firm-year FEs model and one with firm FEs is increasing in the time horizon over which the model is estimated. Finally, we show that increasing dispersion in firm pay is an important factor behind increasing earnings inequality in Sweden over the past 30 years. The increasing dispersion in firm pay is driven by greater permanent dispersion in pay across firms, which in turn is accounted for by greater persistence of pay among incumbent firms and higher firm pay dispersion at firm entry.

While the application to changes in Swedish earnings inequality highlights some of the strengths of our firm-year FEs model, variants of this model can be applied in many other settings. An interesting avenue for future research will be to explore the implications of our empirical findings for equilibrium models of worker and firm dynamics, for the underlying sources of firm pay dynamics, and for designing optimal social insurance policies.

Appendix A. Data

A.1. Detailed dataset descriptions

Worker demographics data (LISA and LOUISE). The LISA and LOUISE databases contain annual data on all adults who are registered in Sweden on December 31 of a given year. For each year, the variable list includes year of birth, gender, highest completed education in a given year including field of study and graduation year, municipality of residence, marital status, number and age of children, and a unique, anonymized individual identifier. We aggregate years of education into five categorical groups, which are defined as whether an individual completed had (1) up to nine years of schooling (Swedish primary school), (2) up to two years of upper secondary high school, (3) up to three years of upper secondary high school, (4) up to two year post-secondary education, and (5) three year and longer post-secondary education, including graduate studies.

Employment register data (RAMS). The RAMS database contains information about all job spells in Sweden since 1985, including gross annual earnings for each spell, start and end month of the employment spell, worker type (employee or self-employed), and some information on the employer, including location and whether it is private or public (in the latter case distinguishing between municipality, region or national government). These data are reported by firms on behalf of workers to Swedish tax authorities for the purpose of tax collection. As such, they arguably suffer from little measurement error. Through unique firm, establishment and individual identifiers, we are able to link these spell data to characteristics of individuals and firms from LISA, LOUISE, and FEK.

Besides calculating monthly gross earnings, we also use these data to impute a measure of firm age, based on the year in which the first individual appeared in the firm. As in many administrative data sets, firm and establishment identifiers sometimes change for reasons such as changes in ownership, etc. We assign a consistent firm and establishment ID by exploiting longitudinal information contained in worker flows.²³

Firm financials data (FEK). The FEK database contains a rich set of annual income and balance sheet data on firms and establishments. SCB collects some form of these data since 1968. Data since 1985 are made available for research purposes. Up to 1997, data were collected only for the largest firms and a sample of smaller firms. Over the 1997–2002 period, coverage was gradually expanded to cover the universe of private sector firms in Sweden.²⁴

The data contain information about firms' sector, revenues, input costs, compensation of employees, assets (long-term and short-term), liabilities (long-term and short-term), equity, investments, etc. Based on these data, we construct a measure of real value added per worker by subtracting costs of intermediates from total sales, converting the difference to real values using the national CPI, and dividing this by total annual firm employment. We similarly proceed to construct real per-worker measures of assets, liabilities, equity and investment.

A.2. Additional statistics on firm dynamics

Autocorrelation of firm mean pay. Table A.1 presents the autocorrelation of firm mean pay between 1985 and 2016.

Firm survival rates. Table A.2 presents survival rates by firm cohorts between 1985 and 2016. According to the firm-level (“unweighted”) statistics in Panel A, between 9.2 and 14.6 percent of all firms exit between two consecutive years. Around 82.6 percent of all firms in 1985 exit by 2016. Looking at the worker-level (“weighted”) statistics in Panel B, between 2.0 and 6.2 percent of all firms exit between two consecutive years, while 43.3 percent of all firms in 1985 have exited by 2016 (in all cases weighing firms by average employment during the years in which they remain active). Together, these statistics suggest two insights. First, there is a large amount of business turnover in the form of firm exit. Second, employment tends to be concentrated at (older and more productive) firms that are less likely to exit.

Appendix B. Measuring firm-year pay heterogeneity

B.1. Details of identification

In this section, we provide details of model identification discussed in Section 3.3 by formalization the definition of a *connected set* in the context of both the original AKM model and our firm-year FE model. To this end, let workers be indexed by $i \in \mathcal{I}$, let firms be indexed by $j \in \mathcal{J}$, and let years be indexed by $t \in \mathcal{T}$. Then let $J : \mathcal{I} \times \mathcal{T} \rightarrow \mathcal{J}$ denote the function identifying for each worker i in year t their current employer $j = J(i, t)$.

²³ For two employers with at least five employees, if a set of workers of size greater than half of the workforce of employer j in year t constitutes more than half of the workforce of employer j' in year $t + 1$, then we classify employers j and j' as the same firm.

²⁴ Data also exist at the level of establishments since 2004, but since both time coverage and the economic content of these data are more limited, we focus on firms as the relevant employer concept.

Table A.1
 Autocorrelation of firm-level mean log earnings at various lag lengths.
 Source: LISA, LOUISE, and RAMS, 1985–2016.

	1985	1986	1987	1988	1989	1990	1991	1992	1993	1994	1995	1996	1997	1998	1999	2000	2001	2002	2003	2004	2005	2006	2007	2008	2009	2010	2011	2012	2013	2014	2015	2016	
<i>Panel A. Unweighted</i>																																	
1985	1.000	0.801	0.755	0.710	0.633	0.620	0.606	0.582	0.573	0.579	0.583	0.575	0.568	0.560	0.553	0.541	0.544	0.529	0.520	0.522	0.514	0.517	0.511	0.493	0.494	0.505	0.509	0.502	0.497	0.494	0.490	0.496	
1986		1.000	0.794	0.727	0.654	0.636	0.617	0.592	0.581	0.585	0.588	0.577	0.571	0.564	0.559	0.545	0.541	0.527	0.515	0.515	0.517	0.513	0.516	0.495	0.491	0.500	0.506	0.504	0.486	0.492	0.489	0.491	
1987			1.000	0.783	0.686	0.661	0.639	0.604	0.588	0.591	0.594	0.587	0.579	0.573	0.573	0.559	0.549	0.539	0.527	0.529	0.525	0.527	0.527	0.516	0.504	0.507	0.520	0.512	0.501	0.497	0.485	0.506	
1988				1.000	0.732	0.693	0.662	0.621	0.603	0.606	0.607	0.599	0.591	0.583	0.576	0.569	0.563	0.549	0.533	0.533	0.522	0.525	0.528	0.512	0.503	0.517	0.523	0.518	0.504	0.497	0.499	0.504	
1989					1.000	0.698	0.644	0.602	0.583	0.583	0.578	0.568	0.564	0.554	0.544	0.534	0.528	0.515	0.508	0.499	0.497	0.497	0.497	0.481	0.472	0.474	0.483	0.486	0.475	0.473	0.471	0.473	
1990						1.000	0.716	0.661	0.635	0.636	0.626	0.615	0.607	0.596	0.580	0.570	0.562	0.549	0.537	0.534	0.534	0.529	0.534	0.520	0.512	0.513	0.524	0.517	0.506	0.510	0.509	0.507	
1991							1.000	0.746	0.704	0.688	0.682	0.664	0.649	0.639	0.627	0.615	0.607	0.594	0.582	0.577	0.567	0.565	0.565	0.558	0.548	0.553	0.558	0.552	0.542	0.547	0.544	0.542	
1992								1.000	0.744	0.713	0.699	0.679	0.658	0.646	0.631	0.621	0.611	0.599	0.586	0.580	0.570	0.572	0.570	0.562	0.554	0.563	0.565	0.559	0.549	0.554	0.550	0.545	
1993									1.000	0.762	0.724	0.704	0.679	0.663	0.643	0.627	0.619	0.607	0.599	0.590	0.576	0.568	0.565	0.561	0.556	0.561	0.567	0.561	0.549	0.559	0.554	0.539	
1994										1.000	0.775	0.734	0.712	0.690	0.666	0.652	0.638	0.631	0.624	0.608	0.603	0.595	0.593	0.582	0.574	0.580	0.585	0.572	0.565	0.567	0.561	0.547	
1995											1.000	0.795	0.754	0.731	0.706	0.684	0.669	0.662	0.652	0.639	0.630	0.623	0.624	0.615	0.603	0.605	0.607	0.599	0.589	0.592	0.582	0.568	
1996												1.000	0.804	0.760	0.728	0.702	0.687	0.674	0.659	0.650	0.640	0.630	0.633	0.622	0.612	0.613	0.611	0.605	0.595	0.600	0.590	0.579	
1997													1.000	0.806	0.753	0.727	0.704	0.689	0.679	0.667	0.662	0.653	0.624	0.615	0.603	0.605	0.607	0.599	0.589	0.592	0.580	0.591	
1998														1.000	0.804	0.758	0.731	0.715	0.703	0.689	0.680	0.669	0.668	0.654	0.641	0.645	0.638	0.634	0.621	0.625	0.616	0.606	
1999															1.000	0.805	0.763	0.740	0.722	0.710	0.699	0.689	0.687	0.669	0.654	0.657	0.650	0.648	0.641	0.631	0.622		
2000																1.000	0.812	0.772	0.750	0.729	0.721	0.710	0.690	0.674	0.668	0.667	0.661	0.651	0.653	0.644	0.636		
2001																	1.000	0.824	0.785	0.764	0.746	0.731	0.729	0.707	0.696	0.687	0.677	0.671	0.671	0.660	0.651		
2002																		1.000	0.825	0.788	0.767	0.751	0.743	0.720	0.707	0.701	0.697	0.690	0.683	0.681	0.672	0.659	
2003																			1.000	0.828	0.793	0.768	0.757	0.735	0.717	0.710	0.707	0.702	0.693	0.691	0.680	0.667	
2004																				1.000	0.833	0.793	0.775	0.752	0.731	0.722	0.718	0.710	0.699	0.698	0.685	0.675	
2005																					1.000	0.833	0.799	0.773	0.751	0.735	0.732	0.722	0.710	0.710	0.700	0.684	
2006																						1.000	0.839	0.795	0.772	0.751	0.747	0.732	0.721	0.722	0.712	0.699	
2007																							1.000	0.843	0.801	0.776	0.769	0.754	0.742	0.740	0.728	0.714	
2008																								1.000	0.841	0.793	0.783	0.767	0.752	0.746	0.736	0.721	
2009																									1.000	0.827	0.801	0.780	0.763	0.753	0.743	0.723	
2010																										1.000	0.845	0.813	0.793	0.779	0.764	0.744	
2011																											1.000	0.850	0.818	0.798	0.787	0.763	
2012																												1.000	0.848	0.817	0.800	0.774	
2013																													1.000	0.850	0.814	0.788	
2014																														1.000	0.846	0.807	
2015																															1.000	0.842	
2016																																1.000	
<i>Panel B. Weighted</i>																																	
1985	1.000	0.913	0.875	0.848	0.814	0.814	0.797	0.802	0.776	0.741	0.795	0.747	0.768	0.750	0.749	0.716	0.734	0.712	0.677	0.690	0.702	0.705	0.702	0.654	0.664	0.679	0.700	0.694	0.690	0.701	0.684	0.691	
1986		1.000	0.897	0.853	0.815	0.818	0.797	0.793	0.770	0.730	0.780	0.736	0.753	0.738	0.736	0.707	0.725	0.684	0.686	0.692	0.709	0.714	0.709	0.663	0.674	0.691	0.699	0.688	0.681	0.694	0.676	0.682	
1987			1.000	0.869	0.830	0.823	0.804	0.794	0.771	0.731	0.783	0.738	0.756	0.745	0.743	0.717	0.735	0.702	0.687	0.699	0.715	0.720	0.718	0.678	0.686	0.698	0.705	0.692	0.686	0.696	0.684	0.690	
1988				1.000	0.856	0.838	0.815	0.794	0.769	0.731	0.783	0.738	0.756	0.745	0.749	0.736	0.715	0.728	0.692	0.674	0.686	0.690	0.692	0.699	0.684	0.686	0.682	0.683	0.673	0.674	0.683	0.669	0.674
1989					1.000	0.833	0.807	0.782	0.754	0.702	0.756	0.717	0.740	0.734	0.725	0.707	0.712	0.686	0.672	0.679	0.685	0.696	0.699	0.673	0.671	0.679	0.680	0.672	0.673	0.683	0.664	0.672	
1990						1.000	0.833	0.805	0.785	0.733	0.782	0.739	0.760	0.752	0.729	0.717	0.724	0.700	0.675	0.686	0.692	0.698	0.705	0.670	0.675	0.689	0.691	0.680	0.676	0.687	0.671	0.676	
1991							1.000	0.857	0.823	0.762	0.814	0.775	0.794	0.790	0.763	0.743	0.762	0.722	0.728	0.720	0.721	0.722	0.728	0.696	0.698	0.710	0.712	0.703	0.718	0.718	0.716	0.714	
1992								1.000	0.864	0.808	0.845	0.802	0.823	0.823	0.800	0.787	0.795	0.722	0.734	0.726	0.725	0.727	0.731	0.705	0.707	0.716	0.709	0.700	0.709	0.713	0.700	0.694	
1993									1.000	0.840	0.871	0.807	0.829	0.832	0.770	0.774	0.771	0.															

Table A.2

Share of firms in year t which are active in year $\tau \geq t$.

Source: RAMS 1985–2016, 1985–2016.

	1985	1986	1987	1988	1989	1990	1991	1992	1993	1994	1995	1996	1997	1998	1999	2000	2001	2002	2003	2004	2005	2006	2007	2008	2009	2010	2011	2012	2013	2014	2015	2016	
<i>Panel A. Unweighted</i>																																	
1985	1.000	0.894	0.818	0.746	0.679	0.635	0.592	0.544	0.498	0.464	0.437	0.415	0.394	0.373	0.354	0.334	0.316	0.297	0.284	0.273	0.262	0.249	0.239	0.231	0.223	0.205	0.197	0.189	0.183	0.177	0.172	0.167	
1986	1.000	1.000	0.896	0.808	0.731	0.681	0.633	0.579	0.530	0.492	0.463	0.440	0.417	0.394	0.374	0.353	0.334	0.314	0.300	0.287	0.276	0.262	0.252	0.243	0.234	0.216	0.207	0.199	0.193	0.186	0.181	0.176	
1987			1.000	0.882	0.791	0.732	0.676	0.617	0.562	0.521	0.489	0.465	0.440	0.415	0.394	0.372	0.352	0.331	0.316	0.303	0.290	0.276	0.265	0.255	0.245	0.226	0.217	0.208	0.202	0.195	0.189	0.184	
1988				1.000	0.878	0.802	0.736	0.668	0.605	0.560	0.526	0.498	0.471	0.444	0.420	0.397	0.376	0.353	0.337	0.322	0.309	0.294	0.282	0.272	0.261	0.240	0.231	0.222	0.215	0.207	0.201	0.195	
1989					1.000	0.892	0.808	0.726	0.655	0.604	0.566	0.536	0.506	0.476	0.450	0.426	0.403	0.378	0.361	0.344	0.330	0.314	0.301	0.289	0.278	0.255	0.245	0.235	0.228	0.220	0.214	0.207	
1990						1.000	0.880	0.778	0.696	0.638	0.597	0.563	0.531	0.499	0.472	0.445	0.420	0.395	0.377	0.360	0.344	0.328	0.314	0.302	0.291	0.266	0.256	0.246	0.238	0.230	0.223	0.216	
1991							1.000	0.862	0.762	0.695	0.647	0.609	0.573	0.537	0.507	0.479	0.452	0.424	0.404	0.385	0.368	0.351	0.336	0.323	0.310	0.283	0.272	0.262	0.253	0.244	0.237	0.230	
1992								1.000	0.864	0.778	0.720	0.675	0.633	0.592	0.558	0.526	0.496	0.465	0.443	0.422	0.403	0.384	0.367	0.353	0.339	0.309	0.298	0.285	0.276	0.266	0.258	0.250	
1993									1.000	0.881	0.806	0.751	0.701	0.653	0.614	0.577	0.544	0.510	0.485	0.461	0.440	0.419	0.400	0.384	0.369	0.337	0.323	0.310	0.300	0.289	0.280	0.272	
1994										1.000	0.889	0.817	0.758	0.703	0.660	0.619	0.582	0.545	0.517	0.491	0.469	0.446	0.425	0.408	0.392	0.358	0.343	0.329	0.318	0.307	0.297	0.288	
1995											1.000	0.896	0.821	0.756	0.706	0.660	0.620	0.580	0.548	0.521	0.496	0.471	0.450	0.432	0.414	0.377	0.362	0.348	0.336	0.324	0.314	0.304	
1996												1.000	0.894	0.816	0.758	0.706	0.660	0.616	0.582	0.552	0.525	0.499	0.476	0.457	0.438	0.399	0.383	0.368	0.355	0.342	0.331	0.321	
1997													1.000	0.889	0.816	0.755	0.702	0.653	0.617	0.584	0.555	0.527	0.502	0.481	0.461	0.420	0.403	0.387	0.373	0.360	0.348	0.337	
1998														1.000	0.894	0.817	0.754	0.698	0.657	0.620	0.589	0.558	0.532	0.509	0.487	0.444	0.426	0.408	0.394	0.379	0.367	0.355	
1999															1.000	0.888	0.810	0.746	0.698	0.657	0.623	0.589	0.560	0.535	0.511	0.466	0.447	0.413	0.397	0.384	0.372		
2000																1.000	0.886	0.804	0.748	0.700	0.661	0.623	0.592	0.564	0.539	0.491	0.470	0.450	0.434	0.418	0.404	0.391	
2001																	1.000	0.895	0.824	0.771	0.722	0.683	0.650	0.619	0.562	0.537	0.513	0.494	0.474	0.459	0.442		
2002																		1.000	0.895	0.824	0.771	0.722	0.683	0.650	0.619	0.562	0.537	0.513	0.494	0.474	0.459	0.442	
2003																			1.000	0.899	0.832	0.775	0.730	0.693	0.659	0.597	0.570	0.544	0.523	0.502	0.485	0.467	
2004																				1.000	0.902	0.832	0.780	0.737	0.699	0.632	0.602	0.574	0.551	0.528	0.510	0.491	
2005																					1.000	0.899	0.833	0.783	0.740	0.666	0.632	0.602	0.578	0.553	0.533	0.513	
2006																						1.000	0.905	0.841	0.789	0.707	0.669	0.636	0.608	0.582	0.560	0.538	
2007																							1.000	0.905	0.839	0.746	0.703	0.666	0.635	0.607	0.583	0.560	
2008																								1.000	0.904	0.794	0.744	0.703	0.668	0.637	0.611	0.586	
2009																									1.000	0.854	0.791	0.743	0.703	0.669	0.639	0.612	
2010																										1.000	0.895	0.830	0.779	0.736	0.701	0.668	
2011																											1.000	0.900	0.835	0.783	0.743	0.706	
2012																												1.000	0.903	0.838	0.789	0.746	
2013																													1.000	0.903	0.838	0.789	0.746
2014																														1.000	0.902	0.841	0.791
2015																															1.000	0.907	0.842
2016																																1.000	0.907
																																	1.000
<i>Panel B. Weighted</i>																																	
1985	1.000	0.980	0.956	0.936	0.914	0.900	0.880	0.846	0.810	0.781	0.743	0.737	0.727	0.713	0.674	0.661	0.650	0.642	0.634	0.627	0.614	0.611	0.606	0.603	0.599	0.593	0.587	0.583	0.575	0.571	0.567	0.564	
1986	1.000	1.000	0.971	0.947	0.923	0.906	0.886	0.851	0.817	0.785	0.746	0.738	0.727	0.714	0.676	0.662	0.649	0.641	0.632	0.624	0.610	0.607	0.602	0.598	0.589	0.583	0.577	0.573	0.565	0.562	0.558	0.555	
1987			1.000	0.959	0.934	0.914	0.891	0.856	0.821	0.790	0.751	0.741	0.729	0.715	0.677	0.663	0.651	0.641	0.632	0.621	0.607	0.603	0.596	0.593	0.589	0.583	0.577	0.570	0.565	0.562	0.558	0.555	
1988				1.000	0.969	0.945	0.921	0.884	0.848	0.814	0.774	0.763	0.749	0.735	0.694	0.679	0.666	0.656	0.646	0.634	0.620	0.616	0.607	0.604	0.599	0.592	0.584	0.580	0.572	0.569	0.564	0.560	
1989					1.000	0.972	0.944	0.904	0.865	0.829	0.788	0.776	0.762	0.746	0.705	0.689	0.676	0.667	0.655	0.643	0.629	0.623	0.614	0.611	0.605	0.598	0.590	0.586	0.577	0.574	0.569	0.565	
1990						1.000	0.965	0.919	0.878	0.840	0.799	0.785	0.770	0.754	0.712	0.697	0.682	0.672	0.660	0.648	0.633	0.627	0.617	0.613	0.608	0.601	0.592	0.585	0.577	0.573	0.568	0.564	
1991							1.000	0.948	0.902	0.861	0.818	0.804	0.788	0.769	0.728	0.711	0.695	0.685	0.671	0.659	0.644	0.637	0.628	0.624	0.618	0.611	0.602	0.595	0.586	0.582	0.577	0.572	
1992								1.000	0.945	0.901	0.856	0.839	0.820	0.799	0.759	0.738	0.720	0.709	0.69														

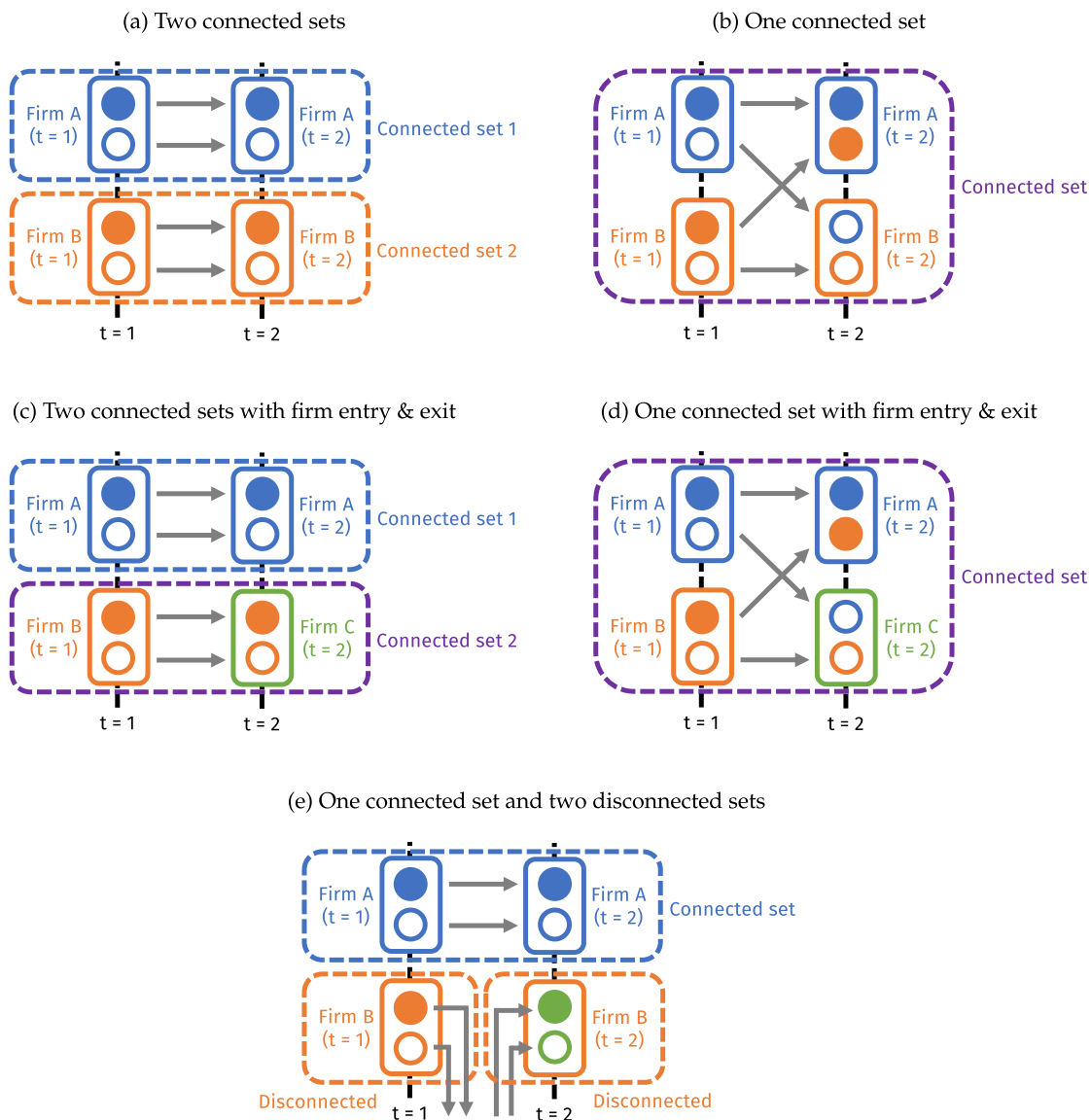

Fig. B.1. Details of illustrating identification of the connected set(s). *Note:* Solid rectangles represent firm-years, with firm A in blue and firm B in orange. Solid and hollow circles represent workers, with worker 1 in solid blue, worker 2 in hollow blue, worker 3 in solid orange, and worker 4 in hollow orange. Vertical dashed lines represent time, with period $t = 1$ to the left and period $t = 2$ to the right. Solid arrows represent worker transitions across firm-years or, in panel (e), out of or into the sample. Dashed rectangles represent the connected set(s) formed by worker transitions across firm-years.

Definition of connected set in AKM framework. Given $(\mathcal{I}, \mathcal{J}, \mathcal{T}, J(\cdot))$, consider the induced set of transitions between physical firms given by

$$\mathcal{E}^{AKM} = \{(j, j') \in \mathcal{J}^2 \mid \exists i \in \mathcal{I}, \exists t, t' \in \mathcal{T} \text{ s.t. } j = J(i, t) \wedge j' = J(i, t')\}.$$

Now consider the (undirected) graph $\mathcal{G}^{AKM} = (\mathcal{J}, \mathcal{E}^{AKM})$ consisting of the vertex set \mathcal{J} and the edge set \mathcal{E}^{AKM} . A *connected set of firms* are the vertices of a maximally connected subgraph of \mathcal{G}^{AKM} . That is, the connected set of firms containing a given firm $j \in \mathcal{J}$ is given by

$$C_j^{AKM} = \bigcup \{C \subseteq \mathcal{J} \mid j \in C \wedge \forall (j', j'') \in C^2 : \exists i \in \mathcal{I}, \exists t', t'' \in \mathcal{T} \text{ s.t. } j' = J(i, t') \wedge j'' = J(i, t'')\}.$$

The *connected set of worker-years* containing a given worker-year $(i, t) \in \mathcal{I} \times \mathcal{T}$ is defined as

$$C_{i,t}^{AKM} = \{(i', t') \in \mathcal{I} \times \mathcal{T} \mid J(i', t') \in C_{J(i,t)}^{AKM}\}.$$

Definition of connected set in firm-year FE framework. The definition of a connected set in the firm-year FE framework proceeds analogously to that in the original AKM framework. Given $(\mathcal{I}, \mathcal{J}, \mathcal{T}, J(\cdot))$, consider the induced set of transitions between firm-years given by

$$\mathcal{E} = \{((j, t), (j', t')) \in (\mathcal{J} \times \mathcal{T})^2 \mid \exists i \in \mathcal{I} \text{ s.t. } j = J(i, t) \wedge j' = J(i, t')\}.$$

Now consider the (undirected) graph $\mathcal{G} = (\mathcal{J} \times \mathcal{T}, \mathcal{E})$ consisting of the vertex set $\mathcal{J} \times \mathcal{T}$ and the edge set \mathcal{E} . A *connected set of firms* are the vertices of a maximally connected subgraph of \mathcal{G} . That is, the connected set of firms containing a given firm-year $(j, t) \in \mathcal{J} \times \mathcal{T}$ is given by

$$C_{j,t} = \bigcup \{C \subseteq \mathcal{J} \times \mathcal{T} \mid (j, t) \in C \wedge \forall ((j', t'), (j'', t'')) \in C^2 : \exists i \in \mathcal{I} \text{ s.t. } j' = J(i, t') \wedge j'' = J(i, t'')\}.$$

The *connected set of worker-years* containing a given worker-year $(i, t) \in \mathcal{I} \times \mathcal{T}$ is defined as

$$C_{i,t} = \{(i', t') \in \mathcal{I} \times \mathcal{T} \mid (J(i', t'), t') \in C_{J(i,t),t}\}.$$

Detailed illustrations. Fig. B.1 illustrates 5 cases of identification of connected sets in the firm-year FE model with two periods (indexed $t = 1, 2$) and two firms (indexed A and B) with two employees each (shown as circles). Panels (a) and (b) are reproduced from Fig. 2 and discussed in Section 3.1. The remaining panels show cases with firm entry and exit, and with worker entry and exit.

Panel (c) illustrates the case of Firm B exiting after period 1 and Firm C appearing as a new entrant in period 2. At the same time, all workers from the exiting Firm B are observed transitioning between periods to the entering Firm C. In this case, two connected sets are formed: one around Firm A across periods, the other around Firm B in period 1 and Firm C in period 2. Indeed, this case is isomorphic to that in panel (a) without firm entry or exit. The reason for this is that in the firm-year FE model, “physical firms” change identity every year, so only the allocation of workers, but not entry and exit of firms, is a meaningful distinction.

Panel (d) illustrates the case of firm entry and exit as in panel (c) but with additional worker mobility between Firm B in period 1 and Firm A in period 2 (and also mobility between Firm A in period 1 and Firm C in period 2, although this is redundant). As a result, one connected set is formed around all firm-years. For the same reason as in the previous paragraph, this case is isomorphic to that in panel (b) without firm entry or exit.

When does a firm-year not form part of a larger connected set? The answer is: whenever it is not connected through worker mobility to any other firm-years. Panel (e) illustrates such a case with worker entry and exit (an analogous example could be constructed with firm entry and exit). Firm B exists for both periods but no worker is observed switching from Firm B in period 1 to any other firm in period 2, and similarly no worker is observed switching to Firm B in period 2 from any other firm in period 1. As a result, both Firm B in period 1 and Firm B in period 2 are disconnected from the rest of the economy, that is, they each lie in a singleton connected set.

Appendix C. Understanding firm pay dynamics

C.1. Autocorrelations of firm pay

Tables C.1–C.4 show the autocorrelation and autocovariance of firm pay in year t and year $t + \tau$, for all years $t = 1985, \dots, 2016$ and $\tau = 0, 1, \dots, 31$, in a weighted and balanced, weighted but unbalanced, balanced but unweighted, and unweighted and unbalanced sample, respectively.

C.2. Robustness of drivers of firm pay dynamics

Table C.5 repeats the analysis in Section 4.3 but without winsorizing the sample at the bottom and top five percent of observations in the regression in changes. Results are qualitatively similar, but somewhat less pronounced quantitatively. This plausibly reflects the fact that the variables in changes contain some outliers.

Appendix D. Using the firm-year FEs model to understand changes in Swedish earnings inequality

This appendix contains additional details about the time series trends in firm pay in Sweden.

D.1. Variance decomposition based on firm-year FEs model estimated on subperiods

Fig. D.1 illustrates the variance decomposition based on the firm-year FEs framework estimated within four subperiods. The variance of the worker FEs rises by roughly four log points over this period, primarily between the first and second subperiod. Yet allowing for changes in the worker FE over time does not much change the estimated increase in the variance of firm-year FEs. In particular, in both the pooled panel and the subperiod specification, the variance of firm-year FEs rises by roughly two log points (although there are some differences in the timing of the increase). We conclude that allowing for worker FEs to change over time does not materially change our conclusion regarding the increase in firm pay dispersion in Sweden over this period.

Table C.2
 Autocorrelation and autocovariance of firm-year FEs at various lag lengths—employment-weighted, unbalanced panel.
 Source: LISA, LOUISE, and RAMS, 1985–2016.

	1985	1986	1987	1988	1989	1990	1991	1992	1993	1994	1995	1996	1997	1998	1999	2000	2001	2002	2003	2004	2005	2006	2007	2008	2009	2010	2011	2012	2013	2014	2015	2016																									
<i>Panel A. Autocorrelation</i>																																																									
1985	1.000	0.862	0.829	0.779	0.714	0.726	0.723	0.685	0.720	0.722	0.780	0.722	0.761	0.736	0.740	0.722	0.725	0.688	0.675	0.689	0.694	0.696	0.685	0.633	0.644	0.646	0.664	0.654	0.627	0.634	0.587	0.580																									
1986		1.000	0.853	0.784	0.718	0.731	0.725	0.682	0.721	0.715	0.769	0.715	0.750	0.727	0.732	0.722	0.726	0.691	0.690	0.692	0.704	0.708	0.694	0.650	0.659	0.663	0.668	0.657	0.626	0.637	0.589	0.581																									
1987			1.000	0.798	0.728	0.720	0.679	0.706	0.684	0.754	0.705	0.740	0.722	0.726	0.718	0.720	0.694	0.684	0.695	0.707	0.714	0.703	0.660	0.670	0.674	0.678	0.665	0.633	0.641	0.599	0.589																										
1988				1.000	0.768	0.750	0.720	0.668	0.692	0.643	0.733	0.672	0.728	0.724	0.716	0.711	0.711	0.673	0.673	0.676	0.686	0.692	0.692	0.657	0.669	0.675	0.671	0.662	0.637	0.642	0.598	0.587																									
1989					1.000	0.768	0.750	0.686	0.635	0.652	0.628	0.696	0.638	0.689	0.688	0.677	0.675	0.671	0.637	0.651	0.651	0.661	0.668	0.663	0.633	0.630	0.645	0.636	0.630	0.603	0.609	0.565	0.554																								
1990						1.000	0.734	0.678	0.696	0.664	0.725	0.666	0.715	0.707	0.680	0.668	0.669	0.637	0.628	0.639	0.649	0.654	0.645	0.603	0.612	0.626	0.622	0.610	0.580	0.583	0.549	0.540																									
1991							1.000	0.754	0.758	0.716	0.782	0.718	0.763	0.756	0.739	0.725	0.732	0.694	0.709	0.704	0.717	0.719	0.712	0.675	0.682	0.706	0.699	0.690	0.658	0.667	0.623	0.618																									
1992								1.000	0.779	0.734	0.785	0.710	0.756	0.741	0.721	0.710	0.704	0.675	0.687	0.681	0.683	0.694	0.682	0.643	0.650	0.671	0.655	0.649	0.621	0.626	0.590	0.573																									
1993									1.000	0.807	0.703	0.763	0.762	0.733	0.733	0.721	0.693	0.704	0.694	0.691	0.689	0.681	0.644	0.654	0.676	0.666	0.660	0.640	0.647	0.611	0.597																										
1994										1.000	0.836	0.755	0.771	0.774	0.698	0.704	0.690	0.691	0.703	0.693	0.692	0.696	0.690	0.647	0.650	0.674	0.664	0.652	0.629	0.634	0.599	0.581																									
1995											1.000	0.796	0.820	0.827	0.776	0.779	0.761	0.737	0.743	0.731	0.734	0.738	0.735	0.686	0.683	0.705	0.691	0.682	0.654	0.665	0.624	0.607																									
1996												1.000	0.863	0.835	0.793	0.786	0.780	0.748	0.760	0.751	0.752	0.755	0.750	0.698	0.707	0.726	0.723	0.712	0.685	0.696	0.657	0.642																									
1997													1.000	0.872	0.817	0.805	0.799	0.764	0.781	0.772	0.764	0.767	0.763	0.712	0.724	0.740	0.739	0.730	0.704	0.711	0.674	0.658																									
1998														1.000	0.845	0.834	0.823	0.788	0.804	0.795	0.783	0.784	0.783	0.730	0.737	0.755	0.748	0.740	0.718	0.725	0.685	0.673																									
1999															1.000	0.860	0.843	0.794	0.811	0.793	0.793	0.799	0.793	0.734	0.749	0.764	0.760	0.752	0.733	0.735	0.695	0.683																									
2000																1.000	0.869	0.816	0.828	0.810	0.813	0.814	0.816	0.753	0.758	0.776	0.773	0.768	0.755	0.759	0.720	0.709																									
2001																	1.000	0.840	0.842	0.823	0.817	0.819	0.823	0.761	0.768	0.785	0.784	0.775	0.767	0.763	0.731	0.708																									
2002																		1.000	0.864	0.837	0.823	0.826	0.823	0.762	0.771	0.793	0.786	0.780	0.774	0.775	0.742	0.727																									
2003																			1.000	0.867	0.849	0.847	0.843	0.784	0.791	0.815	0.807	0.803	0.796	0.798	0.764	0.751																									
2004																				1.000	0.884	0.869	0.858	0.796	0.812	0.828	0.825	0.817	0.806	0.807	0.774	0.763																									
2005																					1.000	0.888	0.868	0.811	0.822	0.833	0.832	0.820	0.807	0.809	0.780	0.764																									
2006																						1.000	0.895	0.829	0.837	0.847	0.849	0.837	0.819	0.822	0.788	0.776																									
2007																							1.000	0.861	0.856	0.864	0.862	0.850	0.835	0.836	0.802	0.790																									
2008																								1.000	0.865	0.830	0.827	0.813	0.795	0.796	0.763	0.753																									
2009																									1.000	0.867	0.855	0.835	0.815	0.818	0.785	0.778																									
2010																										1.000	0.894	0.874	0.856	0.855	0.821	0.807																									
2011																											1.000	0.899	0.876	0.870	0.839	0.825																									
2012																												1.000	0.896	0.879	0.846	0.830																									
2013																													1.000	0.891	0.865	0.840																									
2014																														1.000	0.882	0.864																									
2015																															1.000	0.882	0.864																								
2016																																1.000	0.882	0.864																							
																																	1.000	0.882	0.864																						
																																		1.000	0.882	0.864																					
																																			1.000	0.882	0.864																				
																																				1.000	0.882	0.864																			
																																					1.000	0.882	0.864																		
																																						1.000	0.882	0.864																	
																																							1.000	0.882	0.864																
																																								1.000	0.882	0.864															
																																									1.000	0.882	0.864														
																																										1.000	0.882	0.864													
																																											1.000	0.882	0.864												
																																												1.000	0.882	0.864											
																																													1.000	0.882	0.864										
																																														1.000	0.882	0.864									
																																															1.000	0.882	0.864								
																																																	1.000	0.882	0.864						
																																																		1.000	0.882	0.864					
																																																				1.000	0.882	0.864			
																																																							1.000	0.882	0.864

Table C.3
 Autocorrelation and autocovariance of firm-year FEs at various lag lengths—employment-unweighted, balanced panel.
 Source: LISA, LOUISE, and RAMS, 1985–2016.

	1985	1986	1987	1988	1989	1990	1991	1992	1993	1994	1995	1996	1997	1998	1999	2000	2001	2002	2003	2004	2005	2006	2007	2008	2009	2010	2011	2012	2013	2014	2015	2016	
<i>Panel A. Autocorrelation</i>																																	
1985	1.000	0.780	0.746	0.696	0.585	0.575	0.580	0.564	0.534	0.546	0.543	0.533	0.526	0.513	0.498	0.484	0.467	0.451	0.449	0.430	0.422	0.426	0.418	0.394	0.388	0.367	0.370	0.360	0.333	0.326	0.315	0.298	
1986		1.000	0.787	0.720	0.596	0.592	0.594	0.578	0.545	0.548	0.549	0.533	0.527	0.516	0.505	0.485	0.475	0.458	0.453	0.441	0.437	0.429	0.427	0.400	0.393	0.372	0.378	0.371	0.339	0.335	0.322	0.304	
1987			1.000	0.787	0.650	0.637	0.644	0.622	0.592	0.579	0.587	0.568	0.557	0.546	0.538	0.523	0.508	0.491	0.483	0.473	0.463	0.465	0.457	0.436	0.424	0.403	0.404	0.392	0.362	0.356	0.351	0.337	
1988				1.000	0.707	0.677	0.675	0.651	0.623	0.610	0.619	0.605	0.592	0.579	0.561	0.549	0.532	0.507	0.501	0.489	0.485	0.483	0.477	0.450	0.436	0.423	0.426	0.411	0.382	0.373	0.367	0.346	
1989					1.000	0.638	0.625	0.588	0.554	0.548	0.551	0.534	0.536	0.518	0.500	0.483	0.475	0.453	0.454	0.440	0.441	0.436	0.430	0.402	0.391	0.372	0.376	0.367	0.342	0.335	0.322	0.304	
1990						1.000	0.715	0.672	0.621	0.607	0.610	0.590	0.583	0.563	0.543	0.520	0.513	0.490	0.488	0.465	0.467	0.466	0.465	0.427	0.421	0.411	0.413	0.401	0.372	0.363	0.355	0.336	
1991							1.000	0.792	0.716	0.685	0.675	0.649	0.634	0.628	0.604	0.583	0.578	0.551	0.544	0.528	0.530	0.525	0.522	0.489	0.479	0.473	0.471	0.452	0.425	0.421	0.411	0.387	
1992								1.000	0.782	0.726	0.712	0.682	0.665	0.649	0.630	0.609	0.591	0.565	0.553	0.537	0.538	0.533	0.524	0.490	0.488	0.475	0.477	0.467	0.439	0.435	0.418	0.400	
1993									1.000	0.796	0.752	0.716	0.694	0.672	0.641	0.623	0.606	0.584	0.570	0.555	0.545	0.537	0.528	0.495	0.497	0.485	0.487	0.479	0.450	0.450	0.434	0.407	
1994										1.000	0.807	0.758	0.738	0.708	0.682	0.662	0.640	0.615	0.605	0.587	0.583	0.572	0.562	0.529	0.526	0.516	0.522	0.505	0.475	0.467	0.448	0.425	
1995											1.000	0.830	0.792	0.760	0.723	0.699	0.679	0.655	0.643	0.622	0.623	0.609	0.600	0.562	0.565	0.548	0.547	0.533	0.500	0.497	0.480	0.450	
1996												1.000	0.837	0.797	0.758	0.723	0.706	0.671	0.660	0.645	0.643	0.632	0.622	0.623	0.609	0.600	0.562	0.566	0.556	0.523	0.525	0.502	0.482
1997													1.000	0.836	0.785	0.751	0.727	0.691	0.677	0.656	0.659	0.650	0.639	0.594	0.596	0.580	0.578	0.569	0.537	0.529	0.514	0.486	
1998														1.000	0.835	0.787	0.763	0.728	0.710	0.687	0.683	0.674	0.664	0.620	0.622	0.613	0.606	0.590	0.555	0.558	0.538	0.510	
1999															1.000	0.834	0.797	0.753	0.734	0.710	0.707	0.698	0.687	0.643	0.635	0.625	0.621	0.608	0.578	0.574	0.555	0.526	
2000																1.000	0.845	0.790	0.763	0.731	0.729	0.715	0.704	0.661	0.656	0.641	0.652	0.631	0.606	0.597	0.584	0.559	
2001																	1.000	0.837	0.791	0.761	0.747	0.739	0.724	0.683	0.683	0.664	0.671	0.650	0.621	0.619	0.598	0.567	
2002																		1.000	0.830	0.785	0.771	0.751	0.727	0.688	0.689	0.670	0.678	0.657	0.630	0.625	0.605	0.567	
2003																			1.000	0.832	0.800	0.781	0.754	0.704	0.704	0.686	0.697	0.672	0.646	0.636	0.617	0.586	
2004																				1.000	0.839	0.798	0.772	0.715	0.712	0.696	0.702	0.680	0.651	0.639	0.620	0.589	
2005																					1.000	0.847	0.815	0.756	0.748	0.731	0.730	0.712	0.676	0.668	0.647	0.611	
2006																						1.000	0.855	0.783	0.773	0.751	0.754	0.732	0.695	0.691	0.665	0.633	
2007																							1.000	0.828	0.802	0.773	0.772	0.748	0.710	0.711	0.688	0.647	
2008																								1.000	0.842	0.768	0.769	0.744	0.712	0.705	0.685	0.639	
2009																									1.000	0.825	0.809	0.777	0.744	0.734	0.717	0.673	
2010																										1.000	0.851	0.820	0.776	0.762	0.741	0.696	
2011																											1.000	0.860	0.812	0.790	0.768	0.716	
2012																												1.000	0.852	0.819	0.788	0.741	
2013																													1.000	0.846	0.797	0.753	
2014																														1.000	0.851	0.779	
2015																															1.000	0.835	
2016																																1.000	
<i>Panel B. Autocovariance</i>																																	
1985	0.058	0.046	0.041	0.037	0.036	0.033	0.031	0.030	0.031	0.032	0.031	0.031	0.031	0.029	0.028	0.027	0.025	0.025	0.025	0.024	0.023	0.023	0.023	0.022	0.022	0.020	0.020	0.019	0.018	0.018	0.017		
1986		0.059	0.044	0.039	0.037	0.034	0.032	0.031	0.031	0.032	0.031	0.031	0.031	0.030	0.029	0.028	0.026	0.026	0.025	0.025	0.024	0.023	0.023	0.023	0.022	0.021	0.021	0.020	0.019	0.019	0.018		
1987			0.052	0.040	0.035	0.033	0.031	0.032	0.032	0.032	0.031	0.031	0.031	0.030	0.029	0.028	0.026	0.026	0.025	0.025	0.024	0.024	0.024	0.023	0.022	0.021	0.021	0.020	0.019	0.019	0.018		
1988				0.049	0.040	0.036	0.034	0.032	0.033	0.033	0.033	0.032	0.032	0.032	0.030	0.029	0.028	0.027	0.026	0.026	0.025	0.025	0.024	0.023	0.022	0.021	0.021	0.020	0.019	0.019	0.018		
1989					0.065	0.039	0.036	0.033	0.034	0.034	0.033	0.033	0.033	0.031	0.030	0.029	0.027	0.027	0.026	0.026	0.025	0.025	0.024	0.023	0.022	0.022	0.021	0.020	0.019	0.019	0.018		
1990						0.056	0.038	0.035	0.035	0.034	0.034	0.033	0.033	0.031	0.030	0.028	0.028	0.027	0.027	0.026	0.026	0.025	0.024	0.023	0.022	0.022	0.021	0.020	0.020	0.019	0.019		
1991							0.050	0.039	0.038	0.037	0.036	0.035	0.034	0.033	0.032	0.030	0.029	0.029	0.028	0.028	0.027	0.026	0.026	0.025	0.024	0.024	0.023	0.022	0.022	0.021	0.021		
1992								0.049	0.041	0.039	0.037	0.036	0.035	0.034	0.032	0.031	0.030	0.029	0.028	0.028	0.027	0.026	0.026	0.025	0.024	0.024	0.023	0.023	0.022	0.021	0.021		
1993									0.057	0.046	0.042	0.041	0.040	0.038	0.036	0.034	0.033	0.032	0.031	0.031	0.030	0.029	0.028	0.028	0.027	0.026	0.026	0.025	0.024	0.024	0.023		
1994										0.048	0.042	0.041	0.040	0.038	0.036	0.034	0.033	0.032	0.031	0.031	0.030	0.029	0.028	0.028	0.027	0.026	0.026	0.025	0.024	0.024	0.023		
1995											0.056	0.047	0.045	0.042	0.040	0.038	0.036	0.035	0.034	0.034	0.032	0.032	0.031	0.031	0.030	0.029	0.029	0.027	0.027	0.026	0.025		
1996												0.057	0.048	0.045	0.042	0.040	0.038	0.037	0.036	0.036	0.035	0.034	0.034	0.032	0.032	0.031	0.030	0.030	0.029	0.029	0.028		
1997													0.058	0.047	0.044	0.042	0.040	0.038	0.037	0.037	0.037	0.035	0.035	0.033	0.033	0.032	0.031	0.030	0.030	0.029	0.028		
1998														0.056	0.046	0.042	0.040	0.038	0.037	0.037	0.037	0.036	0.035										

Table C.4
 Autocorrelation and autocovariance of firm-year FEs at various lag lengths—employment-unweighted, unbalanced panel.
 Source: LISA, LOUISE, and RAMS, 1985–2016.

	1985	1986	1987	1988	1989	1990	1991	1992	1993	1994	1995	1996	1997	1998	1999	2000	2001	2002	2003	2004	2005	2006	2007	2008	2009	2010	2011	2012	2013	2014	2015	2016	
<i>Panel A. Autocorrelation</i>																																	
1985	1.000	0.744	0.691	0.636	0.539	0.518	0.506	0.485	0.480	0.485	0.492	0.473	0.463	0.446	0.442	0.427	0.413	0.396	0.387	0.385	0.372	0.373	0.371	0.343	0.337	0.321	0.318	0.309	0.304	0.294	0.279	0.279	
1986		1.000	0.734	0.655	0.561	0.533	0.517	0.497	0.486	0.488	0.494	0.476	0.467	0.453	0.447	0.432	0.417	0.405	0.394	0.393	0.385	0.378	0.379	0.357	0.346	0.328	0.328	0.322	0.302	0.303	0.285	0.283	
1987			1.000	0.714	0.590	0.554	0.533	0.503	0.492	0.492	0.500	0.486	0.475	0.465	0.459	0.447	0.428	0.417	0.411	0.407	0.404	0.397	0.397	0.383	0.367	0.347	0.353	0.336	0.322	0.318	0.310	0.313	
1988				1.000	0.634	0.582	0.548	0.510	0.498	0.500	0.504	0.490	0.479	0.466	0.457	0.451	0.435	0.414	0.404	0.405	0.394	0.394	0.397	0.372	0.360	0.357	0.355	0.342	0.324	0.316	0.309	0.306	
1989					1.000	0.575	0.545	0.474	0.461	0.460	0.461	0.442	0.439	0.425	0.416	0.404	0.396	0.377	0.373	0.366	0.366	0.366	0.364	0.367	0.338	0.330	0.316	0.314	0.309	0.296	0.290	0.275	0.269
1990						1.000	0.590	0.536	0.512	0.511	0.503	0.488	0.475	0.460	0.447	0.431	0.420	0.401	0.391	0.394	0.389	0.381	0.382	0.363	0.352	0.336	0.336	0.323	0.311	0.308	0.298	0.285	
1991							1.000	0.640	0.595	0.570	0.566	0.538	0.518	0.504	0.492	0.475	0.467	0.448	0.438	0.434	0.420	0.421	0.415	0.401	0.397	0.387	0.380	0.371	0.360	0.357	0.347	0.333	
1992								1.000	0.648	0.602	0.587	0.555	0.530	0.510	0.494	0.481	0.467	0.455	0.436	0.435	0.423	0.425	0.412	0.398	0.397	0.393	0.379	0.371	0.363	0.355	0.349	0.335	
1993									1.000	0.663	0.611	0.586	0.559	0.538	0.514	0.491	0.478	0.472	0.463	0.455	0.434	0.422	0.409	0.400	0.401	0.397	0.398	0.388	0.371	0.382	0.365	0.345	
1994										1.000	0.674	0.619	0.595	0.565	0.540	0.516	0.497	0.492	0.484	0.467	0.461	0.446	0.439	0.426	0.418	0.414	0.413	0.395	0.388	0.388	0.370	0.350	
1995											1.000	0.699	0.648	0.618	0.585	0.554	0.534	0.529	0.517	0.505	0.498	0.488	0.483	0.466	0.454	0.447	0.437	0.427	0.412	0.413	0.393	0.371	
1996												1.000	0.718	0.661	0.618	0.583	0.564	0.545	0.532	0.527	0.513	0.502	0.498	0.481	0.474	0.467	0.456	0.451	0.432	0.436	0.412	0.394	
1997													1.000	0.719	0.646	0.618	0.585	0.568	0.555	0.542	0.535	0.527	0.518	0.496	0.491	0.489	0.478	0.469	0.448	0.454	0.432	0.409	
1998														1.000	0.717	0.658	0.623	0.601	0.590	0.572	0.559	0.549	0.541	0.518	0.510	0.509	0.494	0.486	0.466	0.468	0.448	0.434	
1999															1.000	0.721	0.663	0.628	0.606	0.589	0.576	0.572	0.560	0.539	0.524	0.523	0.506	0.501	0.491	0.485	0.464	0.448	
2000																1.000	0.729	0.668	0.644	0.614	0.604	0.595	0.592	0.566	0.549	0.547	0.536	0.526	0.508	0.508	0.487	0.476	
2001																	1.000	0.735	0.677	0.651	0.628	0.618	0.616	0.588	0.575	0.568	0.563	0.549	0.540	0.530	0.510	0.497	
2002																		1.000	0.736	0.681	0.653	0.638	0.628	0.600	0.585	0.581	0.570	0.563	0.548	0.540	0.520	0.504	
2003																			1.000	0.736	0.688	0.654	0.641	0.614	0.596	0.592	0.579	0.570	0.556	0.546	0.527	0.508	
2004																				1.000	0.743	0.687	0.663	0.634	0.609	0.601	0.588	0.577	0.559	0.555	0.530	0.512	
2005																					1.000	0.742	0.692	0.659	0.634	0.612	0.604	0.587	0.570	0.568	0.549	0.528	
2006																						1.000	0.752	0.689	0.660	0.636	0.630	0.611	0.593	0.592	0.574	0.557	
2007																							1.000	0.755	0.697	0.667	0.637	0.617	0.611	0.594	0.571	0.566	
2008																								1.000	0.755	0.684	0.670	0.647	0.625	0.616	0.602	0.580	
2009																									1.000	0.735	0.692	0.662	0.635	0.622	0.606	0.580	
2010																										1.000	0.746	0.699	0.670	0.652	0.633	0.603	
2011																											1.000	0.760	0.712	0.682	0.663	0.631	
2012																												1.000	0.760	0.711	0.682	0.663	
2013																													1.000	0.762	0.705	0.671	
2014																														1.000	0.759	0.704	
2015																															1.000	0.768	
2016																																1.000	
<i>Panel B. Autocovariance</i>																																	
1985	0.084	0.056	0.049	0.045	0.041	0.037	0.037	0.036	0.037	0.037	0.036	0.035	0.034	0.033	0.032	0.030	0.029	0.028	0.027	0.027	0.026	0.025	0.024	0.023	0.023	0.020	0.020	0.019	0.019	0.019	0.018	0.017	
1986		0.082	0.054	0.047	0.043	0.039	0.038	0.037	0.038	0.037	0.036	0.036	0.035	0.033	0.032	0.031	0.029	0.029	0.028	0.028	0.027	0.026	0.025	0.024	0.024	0.021	0.021	0.020	0.020	0.020	0.019	0.018	
1987			0.079	0.051	0.040	0.039	0.037	0.038	0.037	0.036	0.036	0.036	0.035	0.033	0.032	0.031	0.029	0.029	0.028	0.028	0.027	0.026	0.025	0.025	0.025	0.022	0.022	0.021	0.020	0.020	0.019	0.019	
1988				0.080	0.044	0.042	0.041	0.038	0.039	0.038	0.037	0.036	0.035	0.034	0.032	0.030	0.030	0.029	0.028	0.028	0.027	0.026	0.025	0.024	0.024	0.021	0.021	0.021	0.020	0.019	0.019	0.018	
1989					0.089	0.046	0.042	0.039	0.039	0.038	0.036	0.036	0.035	0.033	0.032	0.030	0.030	0.028	0.028	0.028	0.027	0.026	0.025	0.024	0.024	0.021	0.021	0.021	0.020	0.019	0.019	0.018	
1990						0.088	0.049	0.044	0.043	0.042	0.039	0.039	0.037	0.035	0.034	0.032	0.031	0.030	0.029	0.030	0.029	0.028	0.026	0.026	0.024	0.024	0.022	0.022	0.021	0.020	0.020	0.019	
1991							0.101	0.054	0.051	0.047	0.044	0.043	0.041	0.039	0.037	0.035	0.034	0.033	0.033	0.032	0.030	0.030	0.029	0.028	0.029	0.026	0.024	0.024	0.024	0.023	0.023	0.022	
1992								0.107	0.060	0.052	0.048	0.046	0.043	0.041	0.038	0.037	0.035	0.033	0.033	0.032	0.032	0.031	0.029	0.029	0.027	0.025	0.024	0.024	0.024	0.024	0.023	0.022	
1993									0.123	0.066	0.056	0.053	0.050																				

Table C.5
 Relating firm pay to firm fundamentals, no winsorization.
 Source: LISA, LOUISE, RAMS, and FEK, 1997–2016.

	Univariate					Multivariate				
	Level	1-year	3-year	5-year	10-year	Level	1-year	3-year	5-year	10-year
Log capital	0.037 (0.002)	0.010 (0.002)	0.018 (0.002)	0.020 (0.003)	0.026 (0.004)	0.052 (0.003)	0.010 (0.005)	0.017 (0.002)	0.022 (0.004)	0.038 (0.007)
Log number of workers	0.026 (0.003)	-0.004 (0.010)	0.002 (0.007)	-0.000 (0.007)	-0.007 (0.006)	-0.031 (0.003)	-0.005 (0.011)	-0.003 (0.006)	-0.008 (0.007)	-0.021 (0.007)
Log value added per worker	0.140 (0.009)	0.012 (0.005)	0.017 (0.005)	0.023 (0.006)	0.039 (0.008)	0.070 (0.005)	0.010 (0.004)	0.014 (0.004)	0.018 (0.004)	0.024 (0.006)
R^2						0.256	0.004	0.009	0.015	0.044
Firm-years	1,203,530	1,005,640	751,099	568,995	266,726	1,203,530	1,005,640	751,099	568,995	266,726

Note: Univariate and multivariate regression results based on equation (5). The univariate results show the regression coefficient and standard error in parentheses for one independent variable at a time. The multivariate results show the regression coefficients when all independent variables are included in a joint regression. The column labeled “level” shows results when both the dependent and independent variables are contemporaneous. The remaining columns labeled “N-year,” for $N = 1, 3, 5, 10$, shows the N-year within-firm difference in the dependent variable on N-year within-firm difference in the independent variable. All specifications control for year FEs. Firm-year FEs are estimated in the pooled 1985–2016 sample. Standard errors in parenthesis are two-way clustered by firm and year (but not adjusted to reflect first-stage estimation error). Regressions are weighted by average firm employment across the years in which a firm is active.

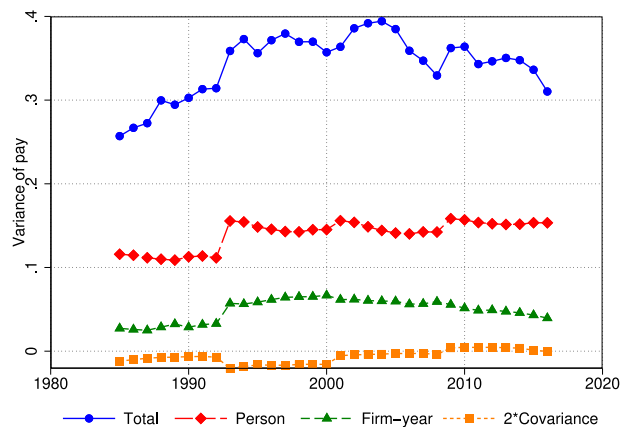

Fig. D.1. Variance decomposition based on firm-year FEs model estimated on subperiods. Note: Figure shows variance decomposition based on the firm-year FEs specification in four 8-year subperiods, 1985–1992, 1993–2000, 2001–2008 and 2009–2016 using the plug-in method. Source: LISA, LOUISE, and RAMS, 1986–2016.

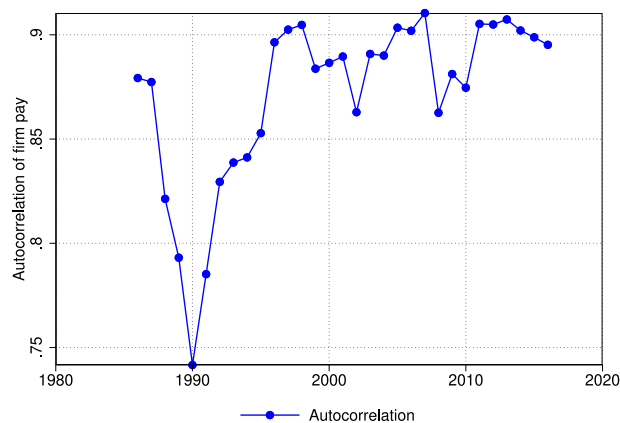

Fig. D.2. 1-Year autocorrelation of firm-year FEs. Note: Figure shows 1-Year autocorrelation of firm-year FEs. All statistics are employment-weighted and use the plug-in method. Source: LISA, LOUISE, and RAMS, 1986–2016.

D.2. Autocorrelation of firm-year FEs over time

Fig. D.2 shows that the autocorrelation of firm-year FEs has risen over time in Sweden, consistent with a greater divergence between the variance of 1-year innovations to firm pay and 5-year innovations to firm-year FEs in Fig. 6.

References

- Abowd, John M., Creedy, Robert H., Kramarz, Francis, 2002. Computing person and firm effects using linked longitudinal employer-employee data. In: Longitudinal Employer-Household Dynamics Technical Paper No. TP-2002-06. In: Center for Economic Studies, U.S. Census Bureau.
- Abowd, John M., Kramarz, Francis, Lengeremann, Paul, Pérez-Duarte, Sébastien, 2004. Are good workers employed by good firms? A test of a simple assortative matching model for France and the United States. Working Paper, Econometric Society.
- Abowd, John M., Kramarz, Francis, Margolis, David N., 1999. High wage workers and high wage firms. *Econometrica* 67 (2), 251–333.
- Alvarez, Jorge, Benguria, Felipe, Engbom, Niklas, Moser, Christian, 2018. Firms and the decline in earnings inequality in Brazil. *Am. Econ. J. Macroecon.* 10 (1), 149–189.
- Andrews, Martyn J., Gill, Leonard, Schank, Thorsten, Upward, Richard, 2008. High wage workers and low wage firms: Negative assortative matching or limited mobility bias? *J. R. Stat. Soc. Series A (Stat. Soc.)* 171 (3), 673–697.
- Andrews, Martyn J., Gill, Leonard, Schank, Thorsten, Upward, Richard, 2012. High wage workers match with high wage firms: Clear evidence of the effects of limited mobility bias. *Econom. Lett.* 117 (3), 824–827.
- Babina, Tania, Ma, Wenting, Moser, Christian, Ouimet, Paige, Zarutskie, Rebecca, 2019. Pay, employment, and dynamics of young firms, Vol.21. Federal Reserve Bank of Minneapolis, Opportunity and Inclusive Growth Institute Working Paper.
- Bagger, Jesper, Lentz, Rasmus, 2018. An empirical model of wage dispersion with sorting. *Rev. Econom. Stud.* 86 (1), 153–190.
- Balke, Neele, Lamadon, Thibaut, 2020. Productivity shocks, long-term contracts and earnings dynamics. Working Paper.
- Bassier, Ihsaan, Dube, Arindrajit, Naidu, Suresh, 2021. Monopsony in movers: The elasticity of labor supply to firm wage policies. *J. Hum. Resour.*
- Bilal, Adrien, Engbom, Niklas, Mongey, Simon, Violante, Giovanni L., 2021. Firm and worker dynamics in a frictional labor market. Working Paper.
- Bonhomme, Stéphane, Holzheu, Kerstin, Lamadon, Thibaut, Manresa, Elena, Mogstad, Magne, Setzler, Bradley, 2021. How much should we trust estimates of firm effects and worker sorting?. IFAU Working Paper No. 2021:20.
- Burdett, Kenneth, Mortensen, Dale T., 1998. Wage differentials, employer size, and unemployment. *Internat. Econom. Rev.* 39 (2), 257–273.
- Card, David, Cardoso, Ana Rute, Heining, Jörg, Kline, Patrick, 2018. Firms and labor market inequality: Evidence and some theory. *J. Labor Econ.* 36 (S1), S13–S70.
- Card, David, Cardoso, Ana Rute, Kline, Patrick, 2016. Bargaining, sorting, and the gender wage gap: Quantifying the impact of firms on the relative pay of women. *Q. J. Econ.* 131 (2), 633–686.
- Card, David, Deicienti, Francesco, Maida, Agata, 2014. Rent-sharing, holdup, and wages: Evidence from matched panel data. *Rev. Econom. Stud.* 81 (1), 84–111.
- Card, David, Heining, Jörg, Kline, Patrick, 2013. Workplace heterogeneity and the rise of west German wage inequality. *Q. J. Econ.* 128 (3), 967–1015.
- Chan, Mons, Xu, Ming, Salgado, Sergio, 2021. Heterogeneous passthrough from TFP to wages. Working Paper, Aarhus University and the University of Minnesota.
- Coles, Melvyn G., Mortensen, Dale T., 2016. Equilibrium labor turnover, firm growth, and unemployment. *Econometrica* 84 (1), 347–363.
- Elsby, Michael W.L., Gottfries, Axel, 2021. Firm dynamics, on-the-job search, and labor market fluctuations. Working Paper.
- Engbom, Niklas, Moser, Christian, 2021. Earnings inequality and the minimum wage: Evidence from Brazil. NBER Working Paper No. 28831.
- Friedrich, Benjamin, Laun, Lisa, Meghir, Costas, Pistaferri, Luigi, 2021. Earnings dynamics and firm-level shocks. NBER Working Paper No. 25786.
- Garin, Andrew, Silvério, Filipe, 2019. How responsive are wages to demand within the firm? Evidence from idiosyncratic export demand shocks. Working Paper.
- Guiso, Luigi, Pistaferri, Luigi, Schivardi, Fabiano, 2005. Insurance within the firm. *J. Polit. Econ.* 113 (5), 1054–1087.
- Haltiwanger, John, Jarmin, Ron S., Miranda, Javier, 2013. Who creates jobs? Small versus large versus young. *Rev. Econ. Stat.* 95 (2), 347–361.
- Hausman, Jerry, 2001. Mismeasured variables in econometric analysis: Problems from the right and problems from the left. *J. Econ. Perspect.* 15 (4), 57–67.
- Kehrig, Matthias, Vincent, Nicolas, 2019. Good dispersion, bad dispersion. NBER Working Paper No. 25923.
- Kline, Patrick, Petkova, Neviana, Williams, Heidi, Zidar, Owen, 2019. Who profits from patents? Rent-sharing at innovative firms. *Q. J. Econ.* 134 (3), 1343–1404.
- Kline, Patrick, Saggio, Raffaele, Sølvsten, Mikkel, 2020. Leave-out estimation of variance components. *Econometrica* 88 (5), 1859–1898.
- Lachowska, Marta, Mas, Alexandre, Saggio, Raffaele, Woodbury, Stephen A., 2021. Do firm effects drift? Evidence from Washington administrative data. NBER Working Paper No. 26653.
- Lemieux, Thomas, MacLeod, W. Bentley, Parent, Daniel, 2009. Performance pay and wage inequality. *Q. J. Econ.* 124 (1), 1–49.
- Lise, Jeremy, Robin, Jean-Marc, 2017. The macrodynamics of sorting between workers and firms. *Amer. Econ. Rev.* 107 (4), 1104–1135.
- Morchio, Iacopo, Moser, Christian, 2020. The gender gap: Micro sources and macro consequences. Working Paper.
- Moscarini, Giuseppe, Postel-Vinay, Fabien, 2012. The contribution of large and small employers to job creation in times of high and low unemployment. *Amer. Econ. Rev.* 102 (6), 2509–2539.
- Moscarini, Giuseppe, Postel-Vinay, Fabien, 2013. Stochastic search equilibrium. *Rev. Econom. Stud.* 80 (4), 1545–1581.
- Moscarini, Giuseppe, Postel-Vinay, Fabien, 2018. The cyclical job ladder. *Annu. Rev. Econ.* 10 (1), 165–188.
- Moser, Christian, Saidi, Farzad, Wirth, Benjamin, Wolter, Stefanie, 2022. Credit supply, firms, and earnings inequality. Working Paper.
- Rosen, Sherwin, 1986. The theory of equalizing differences. *Handb. Labor Econ.* 1, 641–692.
- Song, Jae, Price, David J., Guvenen, Fatih, Bloom, Nicholas, Von Wachter, Till, 2018. Firming up inequality. *Q. J. Econ.* 134 (1), 1–50.
- Sorkin, Isaac, 2018. Ranking firms using revealed preference. *Q. J. Econ.* 133 (3), 1331–1393.
- Van Reenen, John, 1996. The creation and capture of rents: Wages and innovation in a panel of UK companies. *Q. J. Econ.* 111 (1), 195–226.